

Mplus Short Courses
Topic 7

**Multilevel Modeling With Latent
Variables Using Mplus:
Cross-Sectional Analysis**

Linda K. Muthén
Bengt Muthén

Copyright © 2011 Muthén & Muthén

www.statmodel.com

02/11/2011

1

Table Of Contents

General Latent Variable Modeling Framework	7
Analysis With Multilevel Data	11
Complex Survey Data Analysis	15
Intraclass Correlation	16
Design Effects	18
Random Effects ANOVA	19
Two-Level Regression Analysis	29
Two-Level Logistic Regression	60
Two-Level Path Analysis	67
Two-Level Mediation With Random Slopes	80
Two-Level Factor Analysis	86
SIMS Variance Decomposition	92
Exploratory Factor Analysis Of Aggression Items	97
Two-Level IRT	108
Two-Level Factor Analysis With Covariates	109
Multiple Group, Two-Level Factor Analysis	130
Two-Level SEM	147
Two-Level Estimators In Mplus	154
Practical Issues Related To The Analysis Of Multilevel Data	155

2

Table Of Contents (Continued)

Multivariate Approach To Multilevel Modeling	158
Twin Modeling	160
Two-Level Mixture Modeling: Within-Level Latent Classes	162
Regression Mixture Analysis	163
Cluster-Randomized Trials And NonCompliance	177
Latent Class Analysis	183
Multilevel Latent Class Analysis: An Application Of Adolescent Smoking Typologies With Individual And Contextual Predictors	188
Two-Level Mixture Modeling: Between-Level Latent Classes	192
Regression Mixture Analysis	193
Latent Class Analysis	197
References	201

3

Mplus Background

- Inefficient dissemination of statistical methods:
 - Many good methods contributions from biostatistics, psychometrics, etc are underutilized in practice
- Fragmented presentation of methods:
 - Technical descriptions in many different journals
 - Many different pieces of limited software
- Mplus: Integration of methods in one framework
 - Easy to use: Simple, non-technical language, graphics
 - Powerful: General modeling capabilities

4

Mplus Background

- Mplus versions
 - V1: November 1998
 - V2: February 2001
 - V3: March 2004
 - V4: February 2006
 - V5: November 2007
 - V5.21: May 2009
 - V6: April, 2010

- Mplus team: Linda & Bengt Muthén, Thuy Nguyen, Tihomir Asparouhov, Michelle Conn, Jean Maninger

5

Statistical Analysis With Latent Variables A General Modeling Framework

Statistical Concepts Captured By Latent Variables

Continuous Latent Variables

- Measurement errors
- Factors
- Random effects
- Frailties, liabilities
- Variance components
- Missing data

Categorical Latent Variables

- Latent classes
- Clusters
- Finite mixtures
- Missing data

6

Statistical Analysis With Latent Variables A General Modeling Framework (Continued)

Models That Use Latent Variables

Continuous Latent Variables

- Factor analysis models
- Structural equation models
- Growth curve models
- Multilevel models

Categorical Latent Variables

- Latent class models
- Mixture models
- Discrete-time survival models
- Missing data models

Mplus integrates the statistical concepts captured by latent variables into a general modeling framework that includes not only all of the models listed above but also combinations and extensions of these models.

7

General Latent Variable Modeling Framework

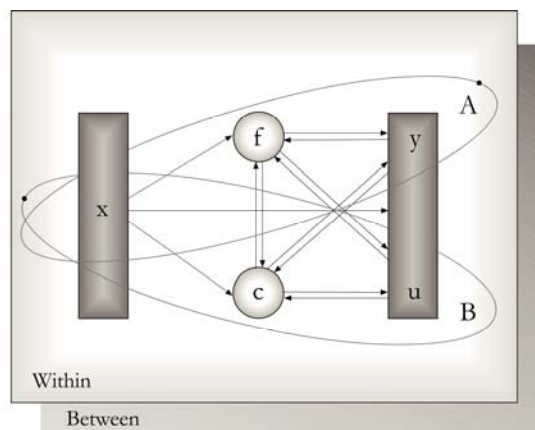

8

Mplus

Several programs in one

- Exploratory factor analysis
- Structural equation modeling
- Item response theory analysis
- Latent class analysis
- Latent transition analysis
- Survival analysis
- Growth modeling
- Multilevel analysis
- Complex survey data analysis
- Monte Carlo simulation

Fully integrated in the general latent variable framework

9

Overview Of Mplus Courses

- **Topic 9.** Bayesian analysis using Mplus. University of Connecticut, May 24, 2011
- Courses taught by other groups in the US and abroad (see the Mplus web site)

10

Analysis With Multilevel Data

11

Analysis With Multilevel Data

Used when data have been obtained by cluster sampling and/or unequal probability sampling to avoid biases in parameter estimates, standard errors, and tests of model fit and to learn about both within- and between-cluster relationships.

Analysis Considerations

- Sampling perspective
 - Aggregated modeling – SUDAAN
 - TYPE = COMPLEX
 - Clustering, sampling weights, stratification (Asparouhov, 2005)

12

Analysis With Multilevel Data (Continued)

- Multilevel perspective
 - Disaggregated modeling – multilevel modeling
 - TYPE = TWOLEVEL
 - Clustering, sampling weights, stratification
 - Multivariate modeling
 - TYPE = GENERAL
 - Clustering, sampling weights
- Combined sampling and multilevel perspective
 - TYPE = COMPLEX TWOLEVEL
 - Clustering, sampling weights, stratification

13

Analysis With Multilevel Data (Continued)

Analysis Areas

- Multilevel regression analysis
- Multilevel path analysis
- Multilevel factor analysis
- Multilevel SEM
- Multilevel growth modeling
- Multilevel latent class analysis
- Multilevel latent transition analysis
- Multilevel growth mixture modeling

14

Complex Survey Data Analysis

15

Intraclass Correlation

Consider nested, random-effects ANOVA for unit i in cluster j ,

$$y_{ij} = \nu + \eta_j + \varepsilon_{ij}; i = 1, 2, \dots, n_j; j = 1, 2, \dots, J. \quad (44)$$

Random sample of J clusters (e.g. schools).

3 examples:

- Students within school (i is student, j is school)
- Time points within individual (i is time point, j is individual)
 - Random intercept growth model
- Indicators per factor (i is indicator, j is individual)
 - Loadings equal to one (Rasch IRT model for dichotomous outcomes), intercepts equal

16

Intraclass Correlation (Continued)

Consider the covariance and variances for cluster members $i = k$ and $i = l$,

$$\text{Cov}(y_{kj}, y_{lj}) = V(\eta), \quad (45)$$

$$V(y_{kj}) = V(y_{lj}) = V(\eta) + V(\varepsilon), \quad (46)$$

resulting in the intraclass correlation

$$\rho(y_{kj}, y_{lj}) = V(\eta) / [V(\eta) + V(\varepsilon)]. \quad (47)$$

Interpretation: Between-cluster variability relative to total variation, intra-cluster homogeneity.

17

NLSY Household Clusters

Household Type (# of respondents)	# of Households*	Intraclass Correlations for Siblings	
		Year	Heavy Drinking
Single	5,944	1982	0.19
Two	1,985	1983	0.18
Three	634	1984	0.12
Four	170	1985	0.09
Five	32	1988	0.04
Six	5	1989	0.06

Total number of households: 8,770

Total number of respondents: 12,686

Average number of respondents per household: 1.4

*Source: NLS User's Guide, 1994, p.247

18

Design Effects

Consider cluster sampling with equal cluster sizes and the sampling variance of the mean.

V_C : correct variance under cluster sampling

V_{SRS} : variance assuming simple random sampling

$V_C \geq V_{SRS}$ but cluster sampling more convenient, less expensive.

$$DEFF = V_C / V_{SRS} = 1 + (s - 1) \rho, \quad (47)$$

where s is the common cluster size and ρ is the intraclass correlation (common range: 0.00 – 0.50).

19

Random Effects ANOVA Example

200 clusters of size 10 with intraclass correlation 0.2 analyzed as:

- TYPE = TWOLEVEL
- TYPE = COMPLEX
- Regular analysis, ignoring clustering

$$DEFF = 1 + 9 * 0.2 = 2.8$$

20

Input For Two-Level Random Effects ANOVA Analysis

```

TITLE:      Random effects ANOVA data
            Two-level analysis with balanced data

DATA:       FILE = anova.dat;

VARIABLE:   NAMES = y cluster;
            USEV = y;
            CLUSTER = cluster;

ANALYSIS:   TYPE = TWOLEVEL;

MODEL:      %WITHIN%
            y;
            %BETWEEN%
            y;

```

21

Output Excerpts Two-Level Random Effects ANOVA Analysis

Model Results

	Estimates	S.E.	Est./S.E.
Within Level			
Variances			
Y	0.779	0.025	31.293
Between Level			
Means			
Y	0.003	0.038	0.076
Variances			
Y	0.212	0.028	7.496

22

Input For Complex Random Effects ANOVA Analysis

```

TITLE:      Random effects ANOVA data
            Complex analysis with balanced data

DATA:      FILE = anova.dat;

VARIABLE:  NAMES = y cluster;
            USEV = y;
            CLUSTER = cluster;

ANALYSIS:  TYPE = COMPLEX;
  
```

23

Output Excerpts Complex Random Effects ANOVA Analysis

Model Results

	Estimates	S.E.	Est./S.E.
Means			
Y	0.003	0.038	0.076
Variances			
Y	0.990	0.036	27.538

24

Input For Random Effects ANOVA Analysis Ignoring Clustering

```

TITLE:      Random effects ANOVA data
            Ignoring clustering

DATA:       FILE = anova.dat;

VARIABLE:   NAMES = y cluster;
            USEV = y;
!          CLUSTER = cluster;

ANALYSIS:

```

25

Output Excerpts Random Effects ANOVA Analysis Ignoring Clustering

Model Results

	Estimates	S.E.	Est./S.E.
Means			
Y	0.003	0.022	0.131
Variances			
Y	0.990	0.031	31.623

Note: The estimated mean has SE = 0.022 instead of the correct 0.038

26

Further Readings On Complex Survey Data

- Asparouhov, T. (2005). Sampling weights in latent variable modeling. Structural Equation Modeling, 12, 411-434.
- Chambers, R.L. & Skinner, C.J. (2003). Analysis of survey data. Chichester: John Wiley & Sons.
- Kaplan, D. & Ferguson, A.J (1999). On the utilization of sample weights in latent variable models. Structural Equation Modeling, 6, 305-321.
- Korn, E.L. & Graubard, B.I (1999). Analysis of health surveys. New York: John Wiley & Sons.
- Patterson, B.H., Dayton, C.M. & Graubard, B.I. (2002). Latent class analysis of complex sample survey data: application to dietary data. Journal of the American Statistical Association, 97, 721-741.
- Skinner, C.J., Holt, D. & Smith, T.M.F. (1989). Analysis of complex surveys. West Sussex, England: Wiley.

27

Further Readings On Complex Survey Data

Stapleton, L. (2002). The incorporation of sample weights into multilevel structural equation models. Structural Equation Modeling, 9, 475-502.

See also the Mplus Complex Survey Data Project:

<http://www.statmodel.com/resrhpap.shtml>

28

Two-Level Regression Analysis

29

Cluster-Specific Regressions

Individual i in cluster j

$$(1) y_{ij} = \beta_{0j} + \beta_{1j} x_{ij} + r_{ij}$$

$$(2a) \beta_{0j} = \gamma_{00} + \gamma_{01} w_j + u_{0j}$$

$$(2b) \beta_{1j} = \gamma_{10} + \gamma_{11} w_j + u_{1j}$$

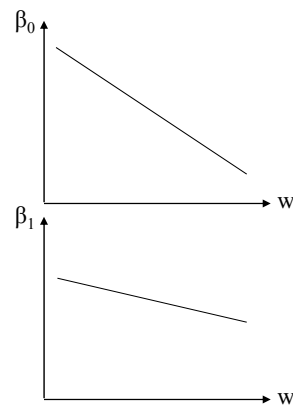
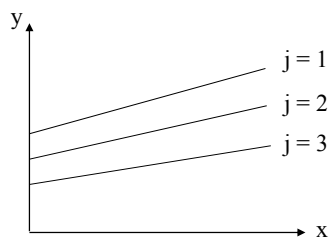

30

Two-Level Regression Analysis With Random Intercepts And Random Slopes In Multilevel Terms

Two-level analysis (individual i in cluster j):

y_{ij} : individual-level outcome variable
 x_{ij} : individual-level covariate
 w_j : cluster-level covariate

Random intercepts, random slopes:

$$\text{Level 1 (Within)} : y_{ij} = \beta_{0j} + \beta_{1j} x_{ij} + r_{ij}, \quad (1)$$

$$\text{Level 2 (Between)} : \beta_{0j} = \gamma_{00} + \gamma_{01} w_j + u_{0j}, \quad (2a)$$

$$\text{Level 2 (Between)} : \beta_{1j} = \gamma_{10} + \gamma_{11} w_j + u_{1j}. \quad (2b)$$

- Mplus gives the same estimates as HLM/MLwiN ML (not REML):
 - $V(r)$ (residual variance for level 1)
 - $\gamma_{00}, \gamma_{01}, \gamma_{10}, \gamma_{11}, V(u_0), V(u_1), \text{Cov}(u_0, u_1)$ (level 2)

31

WITHIN And BETWEEN Options Of The VARIABLE Command

- WITHIN
 - Measured on individual level
 - Modeled on within
 - No variance on between
- BETWEEN
 - Measured on cluster level
 - Modeled on between
- Not on WITHIN or BETWEEN
 - Measured on individual level
 - Modeled on within and between

32

NELS Data

- The data—National Education Longitudinal Study (NELS:88)
 - Base year Grade 8—followed up in Grades 10 and 12
 - Students sampled within 1,035 schools—approximately 26 students per school, $n = 14,217$
 - Variables—reading, math, science, history-citizenship-geography, and background variables

33

NELS Math Achievement Regression

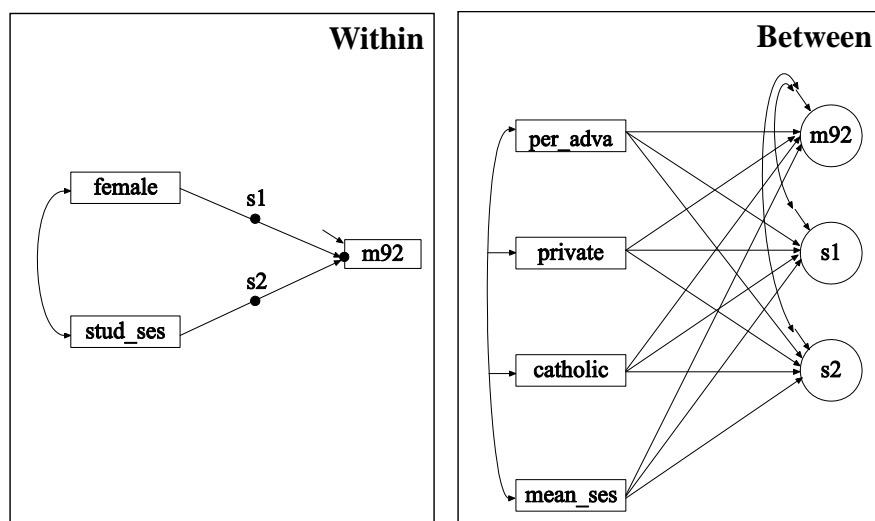

34

Input For NELS Math Achievement Regression

```

TITLE:      NELS math achievement regression

DATA:      FILE IS completev2.dat;
           ! National Education Longitudinal Study (NELS)
           FORMAT IS f8.0 12f5.2 f6.3 f11.4 23f8.2
           f18.2 f8.0 4f8.2;

VARIABLE:  NAMES ARE school r88 m88 s88 h88 r90 m90 s90 h90 r92
           m92 s92 h92 stud_ses f2pnlwt transfer minor coll_asp
           algebra retain aca_back female per_mino hw_time
           salary dis_fair clas_dis mean_col per_high unsafe
           num_frie teaqual par_invo ac_track urban size rural
           private mean_ses catholic stu_teach per_adva tea_exce
           tea_res;

           USEV = m92 female stud_ses per_adva private catholic
           mean_ses;

           !per_adva = percent teachers with an MA or higher

MISSING = blank;
CLUSTER = school;
WITHIN = female stud_ses;
BETWEEN = per_adva private catholic mean_ses;
CENTERING = GRANDMEAN (stud_ses per_adva mean_ses);

```

35

Input For NELS Math Achievement Regression (Continued)

```

ANALYSIS:  TYPE = TWOLEVEL RANDOM;

MODEL:

           %WITHIN%
           s1 | m92 ON female;
           s2 | m92 ON stud_ses;

           %BETWEEN%
           m92 s1 s2 ON per_adva private catholic mean_ses;
           m92 WITH s1 s2;

OUTPUT:    TECH8 SAMPSTAT;

```

36

Output Excerpts NELS Math Achievement Regression

N = 10,933

Summary of Data

Number of clusters 902

Size (s) Cluster ID with Size s

1	89863	75862	52654	1995	32661	89239	56214	
2	41743	81263	45025	26790	60281	82860	56241	21474
	4570	27159	11662	87842	38454			
3	65407	61407	83048	42640	41412	67708	83085	39685
	40402	93469	98582	68595	11517	17543	75498	81069
	66512							
4	31646	68153	85508	26234	83390	60835	74400	20770
	5095	10904	93569	38063	86733	66125	51670	10910
	98461	44395	95317	64112	50880	77381	12835	47555
	9208	93859	35719	67574	20048	34139	25784	80675
5	14464	74791	18219	10468	72193	97616	15773	877
	9471	83234	68254	68028	70718	3496	6842	45854

37

Output Excerpts NELS Math Achievement Regression (Continued)

22	79570	15426	97947	93599	85125	10926	4603
23	6411	60328	70024	67835			
24	36988	22874	50626	19091			
25	56619	59710	34292	18826	62209		
26	44586	67832	16515				
27	82887						
28	847	76909					
30	36177						
31	12786	53660	47120	94802			
32	80553						
34	53272						
36	89842	31572					
42	99516						
43	75115						

Average cluster size 12.187

Estimated Intraclass Correlations for the Y Variables

Intraclass
Variable Correlation

M92 0.107

38

Output Excerpts NELS Math Achievement Regression (Continued)

Tests of Model Fit

```

Loglikelihood
  H0 Value                -39390.404
Information Criteria
  Number of Free parameters      21
  Akaike (AIC)                  78822.808
  Bayesian (BIC)                78976.213
  Sample-Size Adjusted BIC     78909.478
                                (n* = (n + 2) / 24)

```

Model Results

	Estimates	S.E.	Est./S.E.
Within Level			
Residual			
Variances			
M92	70.577	1.149	61.442
Between Level			
S1	ON		
PER_ADVA	0.084	0.841	0.100
PRIVATE	-0.134	0.844	-0.159
CATHOLIC	-0.736	0.780	-0.944
MEAN_SES	-0.232	0.428	-0.542

39

Output Excerpts NELS Math Achievement Regression (Continued)

	Estimates	S.E.	Est./S.E.
S2	ON		
PER_ADVA	1.348	0.521	2.587
PRIVATE	-1.890	0.706	-2.677
CATHOLIC	-1.467	0.562	-2.612
MEAN_SES	1.031	0.283	3.640
M92	ON		
PER_ADVA	0.195	0.727	0.268
PRIVATE	1.505	1.108	1.358
CATHOLIC	0.765	0.650	1.178
MEAN_SES	3.912	0.399	9.814
S1	WITH		
M92	-4.456	1.007	-4.427
S2	WITH		
M92	0.128	0.399	0.322
Intercepts			
M92	55.136	0.185	297.248
S1	-0.819	0.211	-3.876
S2	4.841	0.152	31.900
Residual Variances			
M92	8.679	1.003	8.649
S1	5.740	1.411	4.066
S2	0.307	0.527	0.583

40

Interpretation Of NELS Math Achievement Regression

- Random slope s_1 (math ON female)
 - There are no significant predictors of the random slope s_1 , that is, the effect of gender on student math achievement.
- Random slope s_2 (math ON stud_ses)
 - As the percentage of teachers with advanced degrees increases, the random slope s_2 increases, that is, the effect of student SES on student math achievement increases. This implies that the interaction between teacher quality and SES has an impact on math achievement.
 - Compared to public schools, private and Catholic schools have a lower value of s_2 , that is, the effect of student SES on math achievement is lower for private and Catholic schools. This implies that the interaction between school type and student SES has less of an impact on math achievement in these schools suggesting that private and Catholic schools are more egalitarian than public schools.

41

Interpretation Of NELS Math Achievement Regression (Continued)

- Random slope s_2 (Continued)
 - As school-level SES increases, the random slope s_2 increases, that is the effect of student SES on student math achievement increases. This implies that the interaction between school-level SES and student-level SES has an impact on math achievement.
- Random Intercept m_{92}
 - As school-level SES increases, the random intercept m_{92} increases, that is, school excellence increases.

42

Interpretation Of NELS Math Achievement Regression (Continued)

- Intercepts
 - Means in public schools because of centering per_adv and mean_ses
 - s1 – average regression slope for public schools in the regression of math on female – on average females are lower.
 - s2 – average regression slope for public schools in the regression of math on student SES – on average student SES has a positive influence on math achievement.

43

Cross-Level Influence: Random Intercept

Between-level (level 2) variable w influencing within-level (level 1) y variable:

$$y_{ij} = \beta_{0j} + \beta_1 x_{ij} + r_{ij}$$

$$\beta_{0j} = \underbrace{\gamma_{00} + \gamma_{01} w_j + u_{0j}}$$

i.e. $y_{ij} = \gamma_{00} + \gamma_{01} w_j + u_{0j} + \beta_1 x_{ij} + r_{ij}$

Mplus:

```
MODEL:
  %WITHIN%;
  y ON x; ! estimates beta1
  %BETWEEN%;
  y ON w; ! y is the same as beta0j
           ! estimates gamma01
```

44

Cross-Level Influence: Random Slope

Cross-level interaction, or between-level (level 2) variable moderating a within level (level 1) relationship:

$$y_{ij} = \beta_{0j} + \beta_{1j} x_{ij} + r_{ij}$$

$$\beta_{1j} = \underbrace{\gamma_{10} + \gamma_{11} w_j + u_{1j}}$$

i.e. $y_{ij} = \beta_{0j} + \gamma_{10} x_{ij} + \gamma_{11} w_j x_{ij} + u_{1j} x_{ij} + r_{ij}$

Mplus:

MODEL:

```
%WITHIN%;
beta1 | y ON x;
%BETWEEN%;
beta1 ON w;      ! estimates gamma11
```

45

Random Slopes: Varying Variances

$$y_{ij} = \beta_{0j} + \beta_{1j} x_{ij} + r_{ij}$$

$$\beta_{1j} = \underbrace{\gamma_{10} + \gamma_{11} w_j + u_{1j}}$$

$$V(y_{ij} | x_{ij}, w_j) = V(u_{1j}) x_{ij}^2 + V(r_{ij})$$

The variance varies as a function of the x_{ij} values.

So there is no single population covariance matrix for testing the model fit

46

Random Slopes In Mplus

Mplus allows random slopes for predictors that are

- Observed covariates
- Observed dependent variables
- Continuous latent variables

47

Two-Level Variable Decomposition

$$y_{ij} = \beta_{0j} + \beta_1 x_{ij} + r_{ij}$$

$$\beta_{0j} = \gamma_{00} + \gamma_{01} \bar{x}_{\cdot j} + u_{0j}$$

A random intercept model is the same as decomposing y_{ij} into two uncorrelated components

$$y_{ij} = y_{wij} + y_{bj}$$

where

$$y_{wij} = \beta_1 x_{ij} + r_{ij}$$

$$y_{bj} = \beta_{0j} = \gamma_{00} + \gamma_{01} \bar{x}_{\cdot j} + u_{0j}$$

48

Two-Level Variable Decomposition (Continued)

The same decomposition can be made for x_{ij} ,

$$x_{ij} = x_{wij} + x_{bj}$$

where x_{wij} and x_{bj} are latent covariates,

$$y_{wij} = \beta_w x_{wij} + r_{ij}$$

$$y_{bj} = \gamma_{00} + \beta_b x_{bj} + u_{0j}$$

Mplus can work with either manifest or latent covariates.

See also User's Guide example 9.1.b

49

Bias With Manifest Covariates

Comparing the manifest and latent covariate approach shows a bias in the manifest between-level slope

$$E(\hat{\gamma}_{01}) - \beta_b = (\beta_w - \beta_b) \frac{1}{s} \frac{(1 - icc_x)}{icc_x + (1 - icc_x)/s}$$

Bias increases with decreasing cluster size s and decreasing icc_x .

Example: $(\beta_w - \beta_b) = 0.5$, $s = 10$, $icc_x = 0.1$
gives bias = 0.25

No bias for latent covariate approach

Asparouhov-Muthen (2006), Ludtke et al. (2008)

50

Further Readings On Multilevel Regression Analysis

- Enders, C.K. & Tofighi, D. (2007). Centering predictor variables in cross-sectional multilevel models: A new look at an old Issue. Psychological Methods, 12, 121-138.
- Lüdtke, O., Marsh, H.W., Robitzsch, A., Trautwein, U., Asparouhov, T., & Muthén, B. (2008). The multilevel latent covariate model: A new, more reliable approach to group-level effects in contextual studies. Psychological Methods, 13, 203-229.
- Raudenbush, S.W. & Bryk, A.S. (2002). Hierarchical linear models: Applications and data analysis methods. Second edition. Newbury Park, CA: Sage Publications.
- Snijders, T. & Bosker, R. (1999). Multilevel analysis. An introduction to basic and advanced multilevel modeling. Thousand Oakes, CA: Sage Publications.

51

Logistic And Probit Regression

52

Categorical Outcomes: Logit And Probit Regression

Probability varies as a function of x variables (here x_1, x_2)

$$P(u = 1 | x_1, x_2) = F[\beta_0 + \beta_1 x_1 + \beta_2 x_2], \quad (22)$$

$P(u = 0 | x_1, x_2) = 1 - P[u = 1 | x_1, x_2]$, where $F[z]$ is either the standard normal ($\Phi[z]$) or logistic ($1/[1 + e^{-z}]$) distribution function.

Example: Lung cancer and smoking among coal miners

- u lung cancer ($u = 1$) or not ($u = 0$)
- x_1 smoker ($x_1 = 1$), non-smoker ($x_1 = 0$)
- x_2 years spent in coal mine

53

Categorical Outcomes: Logit And Probit Regression

$$P(u = 1 | x_1, x_2) = F[\beta_0 + \beta_1 x_1 + \beta_2 x_2], \quad (22)$$

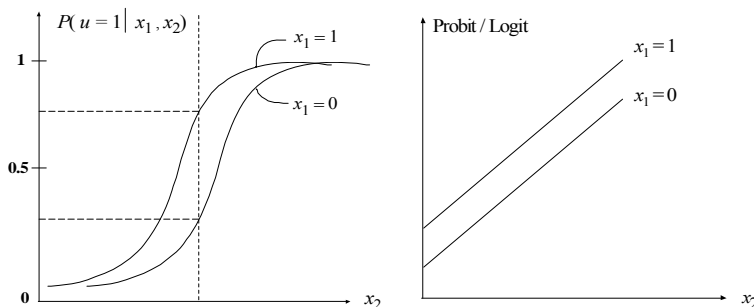

54

Interpreting Logit And Probit Coefficients

- Sign and significance
- Odds and odds ratios
- Probabilities

55

Logistic Regression And Log Odds

$$\begin{aligned} \text{Odds } (u = 1 | x) &= P(u = 1 | x) / P(u = 0 | x) \\ &= P(u = 1 | x) / (1 - P(u = 1 | x)). \end{aligned}$$

The logistic function

$$P(u = 1 | x) = \frac{1}{1 + e^{-(\beta_0 + \beta_1 x)}}$$

gives a log odds linear in x ,

$$\text{logit} = \log [\text{odds } (u = 1 | x)] = \log [P(u = 1 | x) / (1 - P(u = 1 | x))]$$

$$= \log \left[\frac{1}{1 + e^{-(\beta_0 + \beta_1 x)}} / \left(1 - \frac{1}{1 + e^{-(\beta_0 + \beta_1 x)}} \right) \right]$$

$$= \log \left[\frac{1}{1 + e^{-(\beta_0 + \beta_1 x)}} * \frac{1 + e^{-(\beta_0 + \beta_1 x)}}{e^{-(\beta_0 + \beta_1 x)}} \right]$$

$$= \log \left[e^{(\beta_0 + \beta_1 x)} \right] = \beta_0 + \beta_1 x$$

56

Logistic Regression And Log Odds (Continued)

- $\text{logit} = \log \text{odds} = \beta_0 + \beta_1 x$
- When x changes one unit, the *logit* (*log odds*) changes β_1 units
- When x changes one unit, the *odds* changes e^{β_1} units

57

Multinomial Logistic Regression: Polytomous, Unordered (Nominal) Outcome

$$P(u_i = c | x_i) = \frac{e^{\beta_{0c} + \beta_{1c} x_i}}{\sum_{k=1}^K e^{\beta_{0k} + \beta_{1k} x_i}}, \quad (91)$$

for $c = 1, 2, \dots, K$, where we standardize to

$$\beta_{0K} = 0, \quad (92)$$

$$\beta_{1K} = 0, \quad (93)$$

which gives the log odds

$$\log[P(u_i = c | x_i) / P(u_i = K | x_i)] = \beta_{0c} + \beta_{1c} x_i, \quad (94)$$

for $c = 1, 2, \dots, K - 1$, where class K is the reference class

58

Multinomial Logistic Regression Special Case Of K = 2

$$\begin{aligned}
 P(u_i = 1 | x_i) &= \frac{e^{\beta_{01} + \beta_{11} x_i}}{e^{\beta_{01} + \beta_{11} x_i} + 1} \\
 &= \frac{e^{-(\beta_{01} + \beta_{11} x_i)}}{e^{-(\beta_{01} + \beta_{11} x_i)}} * \frac{e^{\beta_{01} + \beta_{11} x_i}}{e^{\beta_{01} + \beta_{11} x_i} + 1} \\
 &= \frac{1}{1 + e^{-(\beta_{01} + \beta_{11} x_i)}}
 \end{aligned}$$

which is the standard logistic regression for a binary outcome.

59

Two-Level Logistic Regression

60

Two-Level Logistic Regression Model

With i denoting individual and j denoting cluster,

$$P(u_{ij} = 1 | x_{ij}) = \frac{1}{1 + e^{-(\beta_{0j} + \beta_{1j} x_{ij})}}$$

$$\text{logit}_{ij} = \log \left[\frac{P(u_{ij} = 1 | x)}{P(u_{ij} = 0 | x)} \right] = \beta_{0j} + \beta_{1j} x_{ij}$$

} Level 1

where

$$\beta_{0j} = \beta_0 + u_{0j}$$

$$\beta_{1j} = \beta_1 + u_{1j}$$

} Level 2

High/low β_{0j} value means high/low logit (high/low log odds)

61

Predicting Juvenile Delinquency From First Grade Aggressive Behavior

- Cohort 1 data from the Johns Hopkins University Preventive Intervention Research Center
- $n = 1,084$ students in 40 classrooms, Fall first grade
- Covariates: gender and teacher-rated aggressive behavior

62

Input For Two-Level Logistic Regression

```

TITLE:
      Hopkins Cohort 1 2-level logistic regression
DATA:
      FILE = Cohort1_classroom_ALL.DAT;
VARIABLE:
      NAMES =  prcid juv99 gender stub1F bkRule1F harm01F
              bkThin1F yell1F takeP1F fight1F lies1F
              tease1F classrm;
      ! juv99:  juvenile delinquency record by age 18
MISSING = ALL (999);
USEVAR = juv99 male aggress;
CATEGORICAL =  juv99;
CLUSTER = classrm;
WITHIN = male aggress;
DEFINE:
      male = 2 - gender;
      aggress = stub1F + bkRule1F + harm01F + bkThin1F +
                yell1F + takeP1F + fight1F + lies1F + tease1F;

```

63

Input For Two-Level Logistic Regression (Continued)

```

ANALYSIS:
      TYPE = TWOLEVEL;
      PROCESS = 2;
MODEL:
      %WITHIN%
      juv99 ON male aggress;
      %BETWEEN%
OUTPUT:
      TECH1 TECH8;

```

64

Output Excerpts Two-Level Logistic Regression

MODEL RESULTS

	Estimates	S.E	Est./S.E.
Within Level			
JUV99	ON		
MALE	1.071	0.149	7.193
AGGRESS	0.060	0.010	6.191
Between Level			
Thresholds			
JUV99\$1	2.981	0.205	14.562
Variances			
JUV99	0.807	0.250	3.228

65

Understanding The Between-Level Intercept Variance

- Intra-class correlation
 - $ICC = 0.807 / (\pi^2 / 3 + 0.807) = 0.20$
- Odds ratios
 - Larsen & Merlo (2005). Appropriate assessment of neighborhood effects on individual health: Integrating random and fixed effects in multilevel logistic regression. American Journal of Epidemiology, 161, 81-88.
 - Larsen proposes MOR:

"Consider two persons with the same covariates, chosen randomly from two different clusters. The MOR is the median odds ratio between the person of higher propensity and the person of lower propensity."

$$MOR = \exp(\sqrt{2 * \sigma^2} * \Phi^{-1}(0.75))$$

In the current example, $ICC = 0.20$, $MOR = 2.36$
- Probabilities
 - Compare $\beta_{0j} = -1$ SD and $\beta_{0j} = +1$ SD from the mean: For males at the aggression mean the probability varies from 0.14 to 0.50

66

Two-Level Path Analysis

67

LSAY Data

- Longitudinal Study of American Youth
- Math and science testing in grades 7 – 12
- Interest in high school dropout
- Data for 2,213 students in 44 public schools

68

A Path Model With A Binary Outcome And A Mediator With Missing Data

Logistic Regression

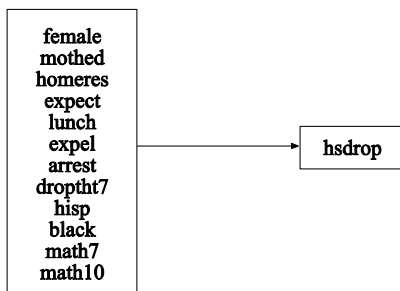

Path Model

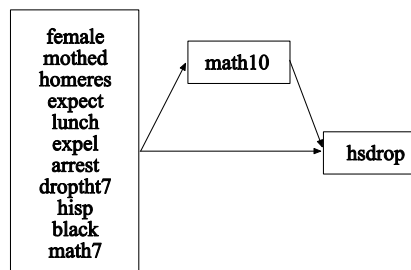

69

Two-Level Path Analysis

Within

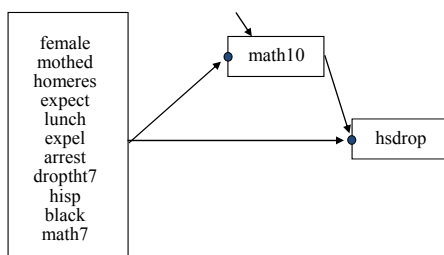

Between



70

Input For A Two-Level Path Analysis Model With A Categorical Outcome And Missing Data On The Mediating Variable

```

TITLE:      a twolevel path analysis with a categorical outcome
            and missing data on the mediating variable
DATA:      FILE = lsayfull_dropout.dat;
VARIABLE:  NAMES = female mothed homeres math7 math10 expel
            arrest hisp black hsdrop expect lunch droptht7
            schcode;
            CATEGORICAL = hsdrop;
            CLUSTER = schcode;
            WITHIN = female mothed homeres expect math7 lunch
            expel arrest droptht7 hisp black;
ANALYSIS:  TYPE = TWOLEVEL;
            ESTIMATOR = ML;
            ALGORITHM = INTEGRATION;
            INTEGRATION = MONTECARLO (500);

```

71

Input For A Two-Level Path Analysis Model With A Categorical Outcome And Missing Data On The Mediating Variable (Continued)

```

MODEL:
    %WITHIN%
    hsdrop ON female mothed homeres expect math7 math10
    lunch expel arrest droptht7 hisp black;
    math10 ON female mothed homeres expect math7 lunch
    expel arrest droptht7 hisp black;

    %BETWEEN%
    hsdrop math10;

OUTPUT:  PATTERNS SAMPSTAT STANDARDIZED TECH1 TECH8;

```

72

Output Excerpts A Two-Level Path Analysis Model With A Categorical Outcome And Missing Data On The Mediating Variable

Summary Of Data

Number of patterns	2
Number of clusters	44

Size (s)	Cluster ID with Size s		
12	304		
13	305		
36	307	122	
38	106	112	
39	138	109	
40	103		
41	308		
42	146	120	
43	102	101	
44	303	143	
45	141		

73

Output Excerpts A Two-Level Path Analysis Model With A Categorical Outcome And Missing Data On The Mediating Variable (Continued)

Size (s)	Cluster ID with Size s					
46	144					
47	140					
49	108					
50	126	111	110			
51	127	124				
52	137	117	147	118	301	136
53	142	131				
55	145	123				
57	135	105				
58	121					
59	119					
73	104					
89	302					
93	309					
118	115					

74

**Output Excerpts A Two-Level Path Analysis Model
With A Categorical Outcome And Missing Data
On The Mediating Variable (Continued)**

Model Results

	Estimates	S.E.	Est./S.E.	Std	StdYX
Within Level					
HSDROP ON					
FEMALE	0.323	0.171	1.887	0.323	0.077
MOTHEd	-0.253	0.103	-2.457	-0.253	-0.121
HOMERES	-0.077	0.055	-1.401	-0.077	-0.061
EXPECT	-0.244	0.065	-3.756	-0.244	-0.159
MATH7	-0.011	0.015	-0.754	-0.011	-0.055
MATH10	-0.031	0.011	-2.706	-0.031	-0.197
LUNCH	0.008	0.006	1.324	0.008	0.074
EXPEL	0.947	0.225	4.201	0.947	0.121
ARREST	0.068	0.321	0.212	0.068	0.007
DROPTHT7	0.757	0.284	2.665	0.757	0.074
HISP	-0.118	0.274	-0.431	-0.118	-0.016
BLACK	-0.086	0.253	-0.340	-0.086	-0.013

75

**Output Excerpts A Two-Level Path Analysis Model
With A Categorical Outcome And Missing Data
On The Mediating Variable (Continued)**

	Estimates	S.E.	Est./S.E.	Std	StdYX
MATH10 ON					
FEMALE	-0.841	0.398	-2.110	-0.841	-0.031
MOTHEd	0.263	0.215	1.222	0.263	0.020
HOMERES	0.568	0.136	4.169	0.568	0.070
EXPECT	0.985	0.162	6.091	0.985	0.100
MATH7	0.940	0.023	40.123	0.940	0.697
LUNCH	-0.039	0.017	-2.308	-0.039	-0.059
EXPEL	-1.293	0.825	-1.567	-1.293	-0.026
ARREST	-3.426	1.022	-3.353	-3.426	-0.054
DROPTHT7	-1.424	1.049	-1.358	-1.424	-0.022
HISP	-0.501	0.728	-0.689	-0.501	-0.010
BLACK	-0.369	0.733	-0.503	-0.369	-0.009

76

Output Excerpts A Two-Level Path Analysis Model With A Categorical Outcome And Missing Data On The Mediating Variable (Continued)

	Estimates	S.E.	Est./S.E.	Std	StdYX
Residual Variances					
MATH10	62.010	2.162	28.683	62.010	0.341
Between Level					
Means					
MATH10	10.226	1.340	7.632	10.226	5.276
Thresholds					
HSDROP\$1	-1.076	0.560	-1.920		
Variances					
HSDROP	0.286	0.133	2.150	0.286	1.000
MATH10	3.757	1.248	3.011	3.757	1.000

77

Two-Level Path Analysis Model Variation

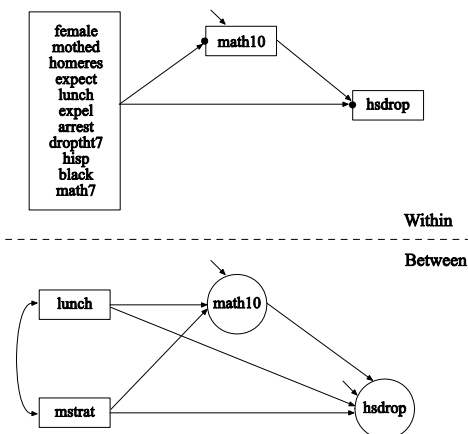

78

Model Diagram For Path Analysis With Between-Level Dependent Variable

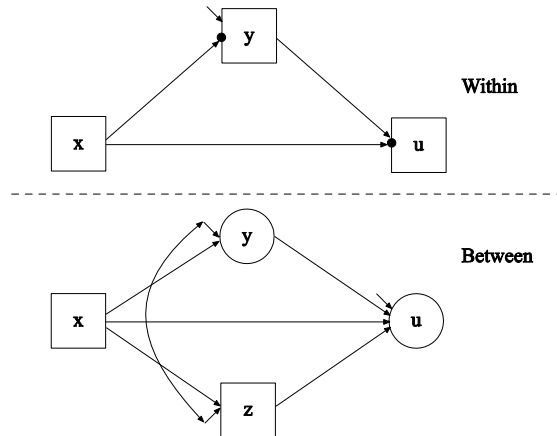

See also Preacher et al. (2010).

79

Two-Level Mediation With Random Slopes

80

Two-Level Mediation

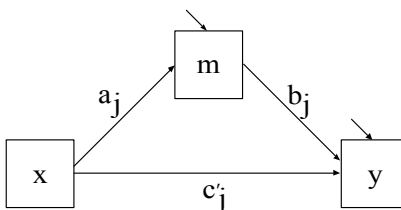

Indirect effect:

$$\alpha * \beta + Cov(a_j, b_j)$$

Bauer, Preacher & Gil (2006). Conceptualizing and testing random indirect effects and moderated mediation in multilevel models: New procedures and recommendations. *Psychological Methods*, 11, 142-163.

81

Input For Two-Level Mediation

```

MONTECARLO:
  NAMES ARE y m x;
  WITHIN = x;
  NOOBSERVATIONS = 1000;
  NCSIZES = 1;
  CSIZES = 100 (10);
  NREP = 100;

MODEL POPULATION:
  %WITHIN%
  c | y ON x;
  b | y ON m;
  a | m ON x;
  x*1; m*1; y*1;
  %BETWEEN%
  y WITH m*0.1 b*0.1 a*0.1 c*0.1;
  m WITH b*0.1 a*0.1 c*0.1;
  a WITH b*0.1 c*0.1;
  b WITH c*0.1;
  y*1 m*1 a*1 b*1 c*1;
  [a*0.4 b*0.5 c*0.6];

```

82

Input For Two-Level Mediation (Continued)

```

ANALYSIS:
      TYPE = TWOLEVEL RANDOM;
MODEL:
      %WITHIN%
      c | y ON x;
      b | y ON m;
      a | m ON x;
      m*1; y*1;
      %BETWEEN%
      y WITH M*0.1 b*0.1 a*0.1 c*0.1;
      m WITH b*0.1 a*0.1 c*0.1;
      a WITH b*0.1 (cab);
      a WITH c*0.1;
      b WITH c*0.1;
      y*1 m*1 a*1 b*1 c*1;
      [a*0.4] (ma);
      [b*0.5] (mb);
      [c*0.6];

MODEL CONSTRAINT:
      NEW(m*0.3);
      m=ma*mb+cab;

```

83

Output Excerpts Two Level Mediation

	Estimates			S.E.	M. S. E.	95%	% Sig
	Population	Average	Std.Dev.	Average		Cover	Coeff
Within Level							
Residual variances							
Y	1.000	1.0020	0.0530	0.0530	0.0028	0.960	1.000
M	1.000	1.0011	0.0538	0.0496	0.0029	0.910	1.000
Between Level							
Y	WITH						
B	0.100	0.1212	0.1246	0.114	0.0158	0.910	0.210
A	0.100	0.1086	0.1318	0.1162	0.0173	0.910	0.190
C	0.100	0.0868	0.1121	0.1237	0.0126	0.940	0.090
M	WITH						
B	0.100	0.1033	0.1029	0.1085	0.0105	0.940	0.120
A	0.100	0.0815	0.1081	0.1116	0.0119	0.950	0.070
C	0.100	0.1138	0.1147	0.1165	0.0132	0.970	0.160
A	WITH						
B	0.100	0.0964	0.1174	0.1101	0.0137	0.920	0.150
C	0.100	0.0756	0.1376	0.1312	0.0193	0.910	0.110

84

Output Excerpts Two-Level Mediation (Continued)

B	WITH							
C		0.100	0.0892	0.1056	0.1156	0.0112	0.960	0.070
Y	WITH							
M		0.100	0.1034	0.1342	0.1285	0.0178	0.940	0.140
Means								
Y		0.000	0.0070	0.1151	0.1113	0.0132	0.950	0.050
M		0.000	-0.0031	0.1102	0.1056	0.0120	0.950	0.050
C		0.600	0.5979	0.1229	0.1125	0.0150	0.930	1.000
B		0.500	0.5022	0.1279	0.1061	0.0162	0.890	1.000
A		0.400	0.3854	0.0972	0.1072	0.0096	0.970	0.970
Variances								
Y		1.000	1.0071	0.1681	0.1689	0.0280	0.910	1.000
M		1.000	1.0113	0.1782	0.1571	0.0316	0.930	1.000
C		1.000	0.9802	0.1413	0.1718	0.0201	0.980	1.000
B		1.000	0.9768	0.1443	0.1545	0.0212	0.950	1.000
A		1.000	1.0188	0.1541	0.1587	0.0239	0.950	1.000
New/Additional Parameters								
M		0.300	0.2904	0.1422	0.1316	0.0201	0.950	0.550

85

Two-Level Factor Analysis

86

Two-Level Factor Analysis

- Recall random effects ANOVA (individual i in cluster j):

$$y_{ij} = \nu + \eta_j + \varepsilon_{ij} = y_{B_j} + y_{W_{ij}}$$

- Two-level factor analysis ($r = 1, 2, \dots, p$ items):

$$y_{rij} = \nu_r + \lambda_{B_r} \eta_{B_j} + \varepsilon_{B_{rj}} + \lambda_{W_r} \eta_{W_{ij}} + \varepsilon_{W_{rij}}$$

(between-cluster variation) (within-cluster variation)

87

Two-Level Factor Analysis (Continued)

- Covariance structure:

$$V(\mathbf{y}) = V(\mathbf{y}_B) + V(\mathbf{y}_W) = \Sigma_B + \Sigma_W,$$

$$\Sigma_B = \mathbf{A}_B \Psi_B \mathbf{A}_B' + \Theta_B,$$

$$\Sigma_W = \mathbf{A}_W \Psi_W \mathbf{A}_W' + \Theta_W.$$

- Two interpretations:
 - variance decomposition, including decomposing the residual
 - random intercept model

88

Two-Level Factor Analysis And Design Effects

Muthén & Satorra (1995; Sociological Methodology): Monte Carlo study using two-level data (200 clusters of varying size and varying intraclass correlations), a latent variable model with 10 variables, 2 factors, conventional ML using the regular sample covariance matrix S_T , and 1,000 replications (d.f. = 34).

$$A_B = A_W = \begin{bmatrix} 1 & 0 \\ 1 & 0 \\ 1 & 0 \\ 1 & 0 \\ 1 & 0 \\ 0 & 1 \\ 0 & 1 \\ 0 & 1 \\ 0 & 1 \\ 0 & 1 \end{bmatrix} \Psi_B, \Theta_B \text{ reflecting different icc's}$$

$$y_{ij} = v + \Lambda(\eta_{Bj} + \eta_{Wij}) + \varepsilon_{Bj} + \varepsilon_{Wij}$$

$$V(y) = \Sigma_B + \Sigma_W = \Lambda(\Psi_B + \Psi_W) \Lambda' + \Theta_B + \Theta_W$$

89

Two-Level Factor Analysis And Design Effects (Continued)

Inflation of χ^2 due to clustering

Intraclass Correlation		Cluster Size			
		7	15	30	60
0.05	Chi-square mean	35	36	38	41
	Chi-square var	68	72	80	96
	5%	5.6	7.6	10.6	20.4
	1%	1.4	1.6	2.8	7.7
0.10	Chi-square mean	36	40	46	58
	Chi-square var	75	89	117	189
	5%	8.5	16.0	37.6	73.6
	1%	1.0	5.2	17.6	52.1
0.20	Chi-square mean	42	52	73	114
	Chi-square var	100	152	302	734
	5%	23.5	57.7	93.1	99.9
	1%	8.6	35.0	83.1	99.4

90

Two-Level Factor Analysis And Design Effects (Continued)

- Regular analysis, ignoring clustering
 - Inflated chi-square, underestimated SE's
- TYPE = COMPLEX
 - Correct chi-square and SE's but only if model aggregates, e.g. $A_B = A_W$
- TYPE = TWOLEVEL
 - Correct chi-square and SE's

91

SIMS Variance Decomposition

The Second International Mathematics Study (SIMS; Muthén, 1991, JEM).

- National probability sample of school districts selected proportional to size; a probability sample of schools selected proportional to size within school district, and two classes randomly drawn within each school
- 3,724 students observed in 197 classes from 113 schools with class sizes varying from 2 to 38; typical class size of around 20
- Eight variables corresponding to various areas of eighth-grade mathematics
- Same set of items administered as a pretest in the Fall of eighth grade and as a posttest in the Spring.

92

SIMS Variance Decomposition (Continued)

Muthén (1991). Multilevel factor analysis of class and student achievement components. *Journal of Educational Measurement*, 28, 338-354.

- Research questions: “The substantive questions of interest in this article are the variance decomposition of the subscores with respect to within-class student variation and between-class variation and the change of this decomposition from pretest to posttest. In the SIMS ... such variance decomposition relates to the effects of tracking and differential curricula in eighth-grade math. On the one hand, one may hypothesize that effects of selection and instruction tend to increase between-class variation relative to within-class variation, assuming that the classes are homogeneous, have different performance levels to begin with, and show faster growth for higher initial performance level. On the other hand, one may hypothesize that eighth-grade exposure to new topics will increase individual differences among students within each class so that posttest within-class variation will be sizable relative to posttest between-class variation.”

93

SIMS Variance Decomposition (Continued)

$$y_{rij} = \nu_r + \lambda_{Br} \eta_{Bj} + \varepsilon_{Brj} + \lambda_{wr} \eta_{wij} + \varepsilon_{wrij}$$

$$V(y_{rij}) = \text{BF} + \text{BE} + \text{WF} + \text{WE}$$

Between reliability: $\text{BF} / (\text{BF} + \text{BE})$

– BE often small (can be fixed at 0)

Within reliability: $\text{WF} / (\text{WF} + \text{WE})$

– sum of a small number of items gives a large WE

Intraclass correlation:

$$\text{ICC} = (\text{BF} + \text{BE}) / (\text{BF} + \text{BE} + \text{WF} + \text{WE})$$

Large measurement error \rightarrow large WE \rightarrow small ICC

True ICC = $\text{BF} / (\text{BF} + \text{WF})$

94

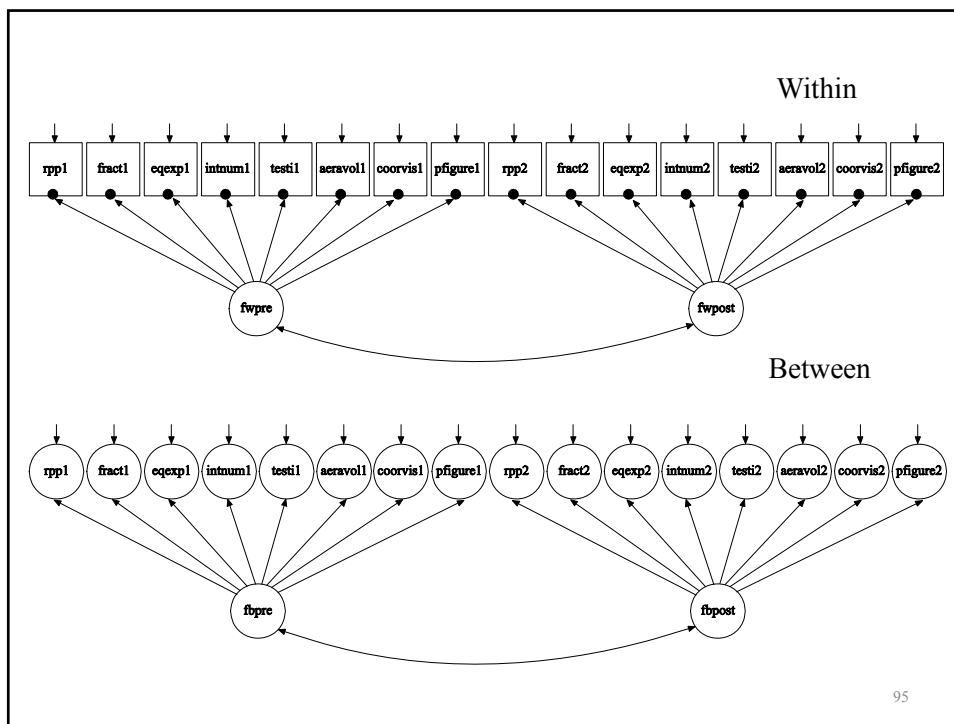

95

Table 4: Variance Decomposition of SIMS Achievement Scores (percentages of total variance in parenthesis)

		ANOVA							FACTOR ANALYSIS				
		Pretest			Posttest			% Increase In Variance		Error-free Prop. Between		Error-free % Increase In Variance	
		Between	Within	Prop-Between	Between	Within	Prop-Between	Between	Within	Pre	Post	Between	Within
RPP	8	1.542 (34.0)	2.990 (66.0)	.34	2.084 (38.5)	3.326 (61.5)	.38	35	11	.54	.52	29	41
FRACT	8	1.460 (38.2)	2.366 (61.8)	.38	1.906 (40.8)	2.767 (59.2)	.41	31	17	.60	.58	29	41
EQEXP	6	.543 (26.9)	1.473 (73.1)	.27	1.041 (38.7)	1.646 (61.3)	.39	92	18	.65	.64	113	117
INTNUM	2	.127 (25.2)	.358 (70.9)	.29	.195 (30.6)	.442 (69.4)	.31	54	24	.63	.61	29	41
TESTI	5	.580 (33.3)	1.163 (66.7)	.33	.664 (34.5)	1.258 (65.5)	.34	15	8	.58	.56	29	41
AREAVOL	2	.094 (17.2)	.451 (82.8)	.17	.156 (24.1)	.490 (75.9)	.24	66	9	.54	.52	29	41
COORVIS	3	.173 (20.9)	.656 (79.1)	.21	.275 (28.7)	.680 (68.3)	.32	59	4	.57	.55	29	41
PFIGURE	5	.363 (22.9)	1.224 (77.1)	.23	.711 (42.9)	1.451 (67.1)	.33	96	19	.60	.54	87	136

96

Exploratory Factor Analysis Of Aggression Items

Item Distributions for Cohort 3: Fall 1st Grade (n=362 males in 27 classrooms)

	<i>Almost Never (scored as 1)</i>	<i>Rarely (scored as 2)</i>	<i>Sometimes (scored as 3)</i>	<i>Often (scored as 4)</i>	<i>Very Often (scored as 5)</i>	<i>Almost Always (scored as 6)</i>
Stubborn	42.5	21.3	18.5	7.2	6.4	4.1
Breaks Rules	37.6	16.0	22.7	7.5	8.3	8.0
Harms Others	69.3	12.4	9.40	3.9	2.5	2.5
Breaks Things	79.8	6.60	5.20	3.9	3.6	0.8
Yells at Others	61.9	14.1	11.9	5.8	4.1	2.2
Takes Others' Property	72.9	9.70	10.8	2.5	2.2	1.9
Fights	60.5	13.8	13.5	5.5	3.0	3.6
Harms Property	74.9	9.90	9.10	2.8	2.8	0.6
Lies	72.4	12.4	8.00	2.8	3.3	1.1
Talks Back to Adults	79.6	9.70	7.80	1.4	0.8	1.4
Teases Classmates	55.0	14.4	17.7	7.2	4.4	1.4
Fights With Classmates	67.4	12.4	10.2	5.0	3.3	1.7
Loses Temper	61.6	15.5	13.8	4.7	3.0	1.4

97

Hypothesized Aggressiveness Factors

- Verbal aggression
 - Yells at others
 - Talks back to adults
 - Loses temper
 - Stubborn
- Property aggression
 - Breaks things
 - Harms property
 - Takes others' property
 - Harms others
- Person aggression
 - Fights
 - Fights with classmates
 - Teases classmates

98

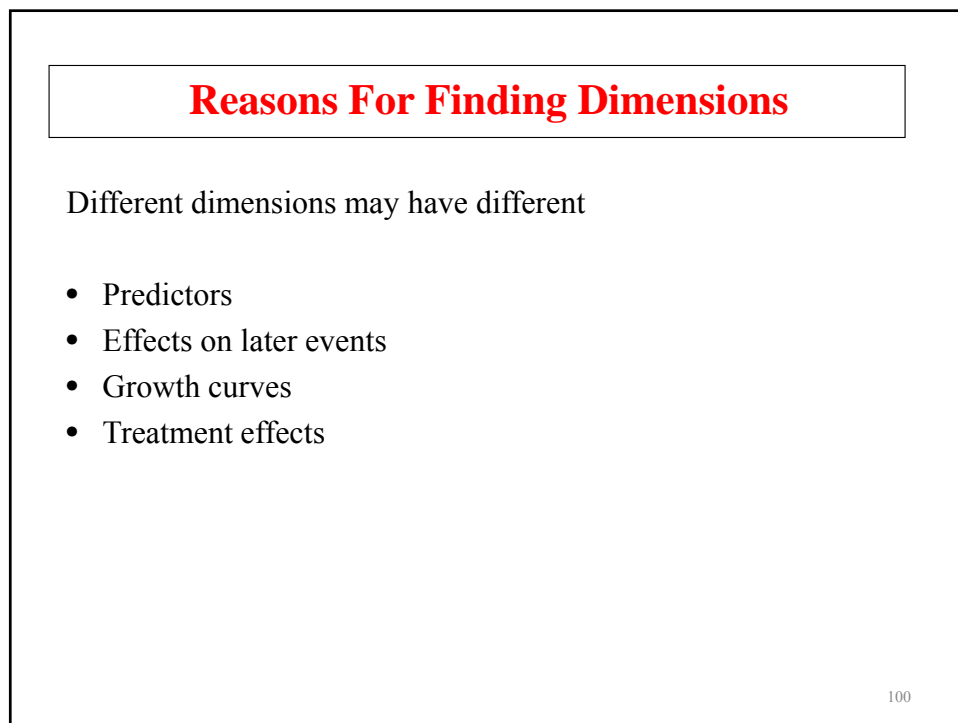
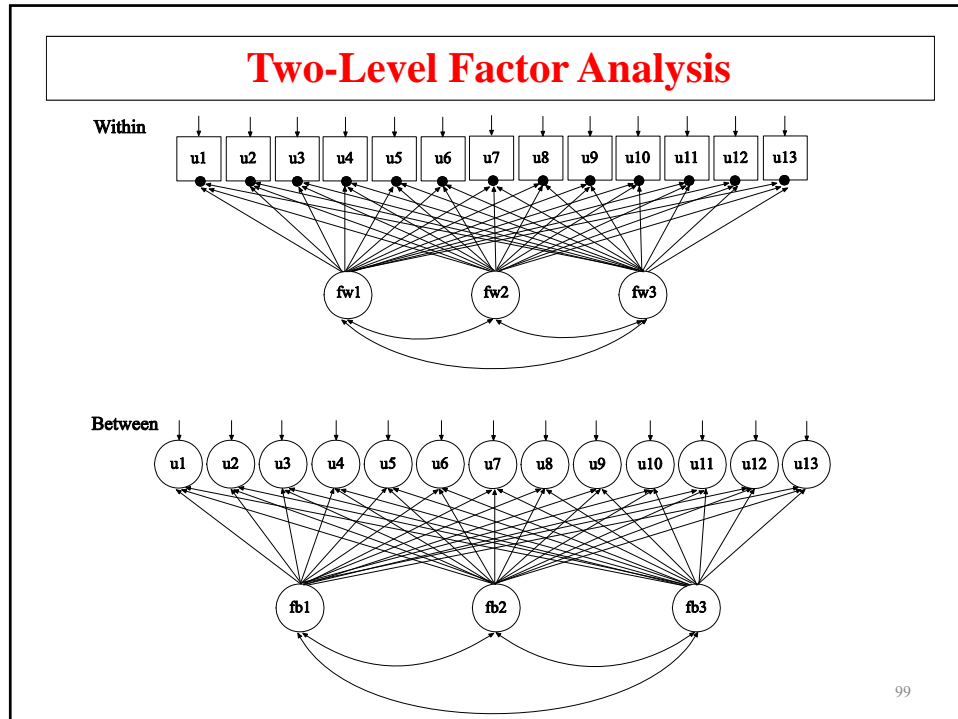

Categorical Outcomes, Latent Dimensions, And Computational Demand

- ML requires numerical integration (see end of Topic 8)
 - increasingly time consuming for increasing number of continuous latent variables and increasing sample size
- Bayes analysis
- Limited information weighted least squares estimation

101

Two-Level Weighted Least Squares

- New simple alternative (Asparouhov & Muthén, 2007):
 - computational demand virtually independent of number of factors/random effects
 - high-dimensional integration replaced by multiple instances of one- and two-dimensional integration
 - possible to explore many different models in a time-efficient manner
 - generalization of the Muthen (1984) single-level WLS
 - variables can be categorical, continuous, censored, combinations
 - residuals can be correlated (no conditional independence assumption)
 - model fit chi-square testing
 - can produce unrestricted level 1 and level 2 correlation matrices for EFA

102

Input For Two-Level EFA of Aggression Using WLSM And Geomin Rotation

```

TITLE:    two-level EFA of 13 TOCA aggression items

DATA:     FILE IS Muthen.dat;

VARIABLE: NAMES ARE id race lunch312 gender u1-u13 sgsf93;
          MISSING are all (999);
          USEOBS = gender eq 1;  !males
          USEVARIABLES = u1-u13;
          CATEGORICAL = u1-u13;
          CLUSTER = sgsf93;

ANALYSIS: TYPE = TWOLEVEL EFA 1 3 UW 1 3 UB;
          PROCESS = 4;

SAVEDATA: SWMATRIX = sw.dat;

```

103

Output Excerpts Two-Level EFA of Aggression Using WLSM And Geomin Rotation

```

Number of clusters                27

Average cluster size              13.407

Estimated Intraclass Correlations for the Y Variables

```

Variable	Intraclass Correlation	Variable	Intraclass Correlation	Variable	Intraclass Correlation
U1	0.110	U2	0.121	U3	0.208
U4	0.378	U5	0.213	U6	0.250
U7	0.161	U8	0.315	U9	0.208
U10	0.140	U11	0.178	U12	0.162
U13	0.172				

104

Two-Level EFA Model Test Result For Aggressive-Disruptive Items

Within-level		Between-level			
Factors	Factors	Df	Chi-Square	CFI	RMSEA
unrestricted	1	65	66 (p=0.43)	1.000	0.007
1	1	130	670	0.991	0.107
2	1	118	430	0.995	0.084
3	1	107	258	0.997	0.062
4*	1	97	193	0.998	0.052

*4th factor has no significant loadings

105

Two-Level EFA Of Aggressive-Disruptive Items: Geomin Rotated Factor Loading Matrix

	Within-Level Loadings			Between-Level Loadings
	Property	Verbal	Person	General
Stubborn	0.00	0.78*	0.01	0.65*
Breaks Rules	0.31*	0.25*	0.32*	0.61*
Harms Others and Property	0.64*	0.12	0.25*	0.68*
Breaks Things	0.98*	0.08	-0.12*	0.98*
Yells At Others	0.11	0.67*	0.10	0.93*
Takes Others' Property	0.73*	-0.15*	0.31*	0.80*
Fights	0.10	0.03	0.86*	0.79*
Harms Property	0.81*	0.12	0.05	0.86*
Lies	0.60*	0.25*	0.10	0.86*
Talks Back To Adults	0.09	0.78*	0.05	0.81*
Teases Classmates	0.12	0.16*	0.59*	0.83*
Fights With Classmates	-0.02	0.13	0.88*	0.84*
Loses Temper	-0.02	0.85*	0.05	0.87*

106

IRT

Single-level IRT:

$$P(u_{ik} = 1 \mid \theta_i, a_k, b_k) = \Phi(a_k \theta_i - b_k), \quad (1)$$

for individual i and item k .

- a is discrimination (slope)
- b is difficulty
- θ is the ability (continuous latent variable)

107

Two-Level IRT (Fox, 2005)

Two-level IRT (Fox, 2005, p.21; Fox & Glas, 2001):

$$P(u_{ijk} = 1 \mid \theta_{ij}, a_k, b_k) = \Phi(a_k \theta_{ij} - b_k), \quad (1)$$

for individual i , cluster j , and item k .

$$\left. \begin{aligned} \theta_{ij} &= \beta_{0j} + \beta_{1j} SES_{ij} + \beta_{2j} Gender_{ij} + \beta_{3j} IQ_{ij} + e_{ij}, \\ \beta_{0j} &= \gamma_{00} + \gamma_{1j} Leader_j + \gamma_{02} Climate_j + u_{0j}, \\ \beta_{1j} &= \gamma_{10}, \\ \beta_{2j} &= \gamma_{20}, \\ \beta_{3j} &= \gamma_{30} \end{aligned} \right\} (21)$$

108

Two-Level Factor Analysis With Covariates

109

Two-Level Factor Analysis With Covariates

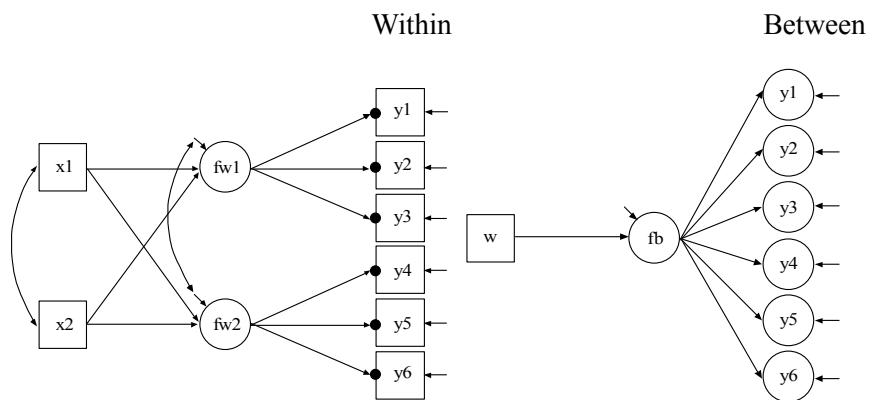

110

Input For Two-Level Factor Analysis With Covariates

```

TITLE:      this is an example of a two-level CFA with
             continuous factor indicators with two factors on the
             within level and one factor on the between level

DATA:      FILE IS ex9.8.dat;

VARIABLE:  NAMES ARE y1-y6 x1 x2 w clus;
           WITHIN = x1 x2;
           BETWEEN = w;
           CLUSTER IS clus;

ANALYSIS:  TYPE IS TWOLEVEL;

MODEL:     %WITHIN%
           fw1 BY y1-y3;
           fw2 BY y4-y6;
           fw1 ON x1 x2;
           fw2 ON x1 x2;
           %BETWEEN%
           fb BY y1-y6;
           fb ON w;

```

111

Input For Monte Carlo Simulations For Two-Level Factor Analysis With Covariates

```

TITLE:      This is an example of a two-level CFA with
             continuous factor indicators with two
             factors on the within level and one factor
             on the between level

MONTECARLO:
           NAMES ARE y1-y6 x1 x2 w;
           NOBSERVATIONS = 1000;
           NCSIZES = 3;
           CSIZES = 40 (5) 50 (10) 20 (15);
           SEED = 58459;
           NREPS = 1;
           SAVE = ex9.8.dat;
           WITHIN = x1 x2;
           BETWEEN = w;

ANALYSIS:  TYPE = TWOLEVEL;

```

112

Input For Monte Carlo Simulations For Two-Level Factor Analysis With Covariates (Continued)

```

MODEL POPULATION:
    %WITHIN%
    x1-x2@1;
    fw1 BY y1@1 y2-y3*1;
    fw2 BY y4@1 y5-y6*1;
    fw1-fw2*1;
    y1-y6*1;
    fw1 ON x1*.5 x2*.7;
    fw2 ON x1*.7 x2*.5;

    %BETWEEN%
    [w@0]; w*1;
    fb BY y1@1 y2-y6*1;
    y1-y6*.3;
    fb*.5;
    fb ON w*1;

```

113

Input For Monte Carlo Simulations For Two-Level Factor Analysis With Covariates (Continued)

```

MODEL:
    %WITHIN%

    fw1 BY y1@1 y2-y3*1;
    fw2 BY y4@1 y5-y6*1;
    fw1-fw2*1;
    y1-y6*1;
    fw1 ON x1*.5 x2*.7;
    fw2 ON x1*.7 x2*.5;

    %BETWEEN%

    fb BY y1@1 y2-y6*1;
    y1-y6*.3;
    fb*.5;
    fb ON w*1;

OUTPUT:
    TECH8 TECH9;

```

114

Further Readings On Monte Carlo Simulations

- Muthén, L.K. & Muthén, B.O. (2002). How to use a Monte Carlo study to decide on sample size and determine power. *Structural Equation Modeling*, 4, 599-620.
- User's Guide chapter 11
- Monte Carlo counterparts to User's Guide examples

115

NELS Two-Level Longitudinal Factor Analysis With Covariates

Within

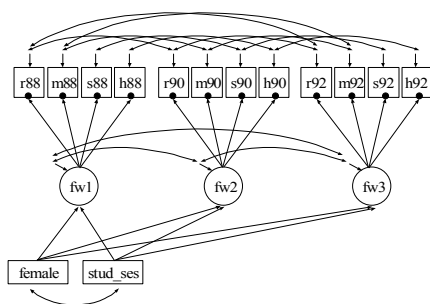

Between

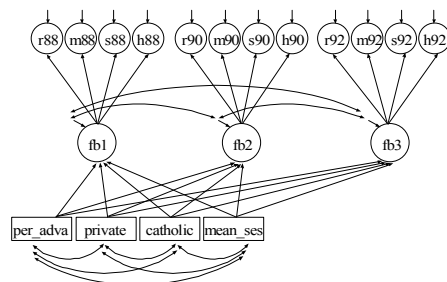

116

NELS Data

- The data—National Education Longitudinal Study (NELS:88)
 - Base year Grade 8—followed up in Grades 10 and 12
 - Students sampled within 1,035 schools—approximately 26 students per school, n = 14,217
 - Variables—reading, math, science, history-citizenship-geography, and background variables
- Data for the analysis—reading, math, science, history-citizenship-geography

117

Input For NELS Two-Level Longitudinal Factor Analysis With Covariates

```

TITLE:      two-level factor analysis with covariates using the NELS
            data

DATA:       FILE = NELS.dat;
            FORMAT = 2f7.0 f11.4 12f5.2 11f8.2;

VARIABLE:   NAMES = id school f2pnlwt r88 m88 s88 h88 r90 m90 s90 h90
            r92 m92 s92 h92 stud_ses female per_mino urban size rural
            private mean_ses catholic stu_tec per_adva;
            !Variable Description
            !m88 = math IRT score in 1988
            !m90 = math IRT score in 1990
            !m92 = math IRT score in 1992
            !r88 = reading IRT score in 1988
            !r90 = reading IRT score in 1990
            !r92 = reading IRT score in 1992

```

118

Input For NELS Two-Level Longitudinal Factor Analysis With Covariates (Continued)

```

!s88 = science IRT score in 1988
!s90 = science IRT score in 1990
!s92 = science IRT score in 1992
!h88 = history IRT score in 1988
!h90 = history IRT score in 1990
!h92 = history IRT score in 1992
!female = scored 1 vs 0
!stud_ses = student family ses in 1990 (flses)
!per_adva = percent teachers with an MA or higher
!private = private school (scored 1 vs 0)
!catholic = catholic school (scored 1 vs 0)
!private = 0, catholic = 0 implies public school

MISSING = BLANK;
CLUSTER = school;

USEV = r88 m88 s88 h88 r90 m90 s90 h90 r92 m92 s92 h92
female stud_ses per_adva private catholic mean_ses;
WITHIN = female stud_ses;
BETWEEN = per_adva private catholic mean_ses;

```

119

Input For NELS Two-Level Longitudinal Factor Analysis With Covariates (Continued)

```

ANALYSIS: TYPE = TWOLEVEL;
MODEL: %WITHIN%
fw1 BY r88-h88;
fw2 BY r90-h90;
fw3 BY r92-h92;
r88 WITH r90; r90 WITH r92; r88 WITH r92;
m88 WITH m90; m90 WITH m92; m88 WITH m92;
s88 WITH s90; s90 WITH s92;
h88 WITH h90; h90 WITH h92;
fw1-fw3 ON female stud_ses;

%BETWEEN%
fb1 BY r88-h88;
fb2 BY r90-h90;
fb3 BY r92-h92;
fb1-fb3 ON per_adva private catholic mean_ses;
OUTPUT: SAMPSTAT STANDARDIZED TECH1 TECH8 MODINDICES;

```

120

Output Excerpts NELS Two-Level Longitudinal Factor Analysis With Covariates (Continued)

Information Criteria

Number of Free Parameters	94
Akaike (AIC)	974835.554
Bayesian (BIC)	975546.400
Sample-Size Adjusted BIC ($n^* = (n + 2) / 24$)	975247.676
RMSEA (Root Mean Square Error Of Approximation)	
Estimate	0.048
SRMR (Standardized Root Mean Square Residual)	
Value for Between	0.041
Value for Within	0.027

123

Output Excerpts NELS Two-Level Longitudinal Factor Analysis With Covariates (Continued)

Model Results

		Estimates	S.E.	Est./S.E.	Std	StdYX
Within Level						
FW1	BY					
R88		1.000	0.000	0.000	6.528	0.812
M88		0.940	0.010	94.856	6.135	0.804
S88		1.005	0.010	95.778	6.559	0.837
H88		1.041	0.011	97.888	6.796	0.837
FW2	BY					
R90		1.000	0.000	0.000	8.038	0.842
M90		0.911	0.008	109.676	7.321	0.838
S90		1.003	0.010	99.042	8.065	0.859
H90		0.939	0.008	113.603	7.544	0.855

124

Output Excerpts NELS Two-Level Longitudinal Factor Analysis With Covariates (Continued)

FW3	BY					
R92		1.000	0.000	0.000	8.460	0.832
M92		0.939	0.009	101.473	7.946	0.845
S92		1.003	0.011	90.276	8.482	0.861
H92		0.934	0.009	102.825	7.905	0.858
FW1	ON					
FEMALE		-0.403	0.128	-3.150	-0.062	-0.031
STUD_SES		3.378	0.096	35.264	0.517	0.418
FW2	ON					
FEMALE		-0.621	0.157	-3.945	-0.077	-0.039
STUD_SES		4.169	0.110	37.746	0.519	0.420
FW3	ON					
FEMALE		-1.027	0.169	-6.087	-0.121	-0.064
STUD_SES		4.418	0.122	36.124	0.522	0.422

125

Output Excerpts NELS Two-Level Longitudinal Factor Analysis With Covariates (Continued)

Residual Variances						
R88		22.021	0.383	57.464	22.021	0.341
M88		20.618	0.338	61.009	20.618	0.354
S88		18.383	0.323	56.939	18.383	0.299
H88		19.805	0.370	53.587	19.805	0.300
R90		26.546	0.491	54.033	26.546	0.291
M90		22.756	0.375	60.748	22.756	0.298
S90		23.150	0.383	60.516	23.150	0.262
H90		21.002	0.403	52.124	21.002	0.270
R92		31.821	0.617	51.562	31.821	0.308
M92		25.213	0.485	52.018	25.213	0.285
S92		25.155	0.524	47.974	25.155	0.259
H92		22.479	0.489	46.016	22.479	0.265
FW1		35.081	0.699	50.201	0.823	0.823
FW2		53.079	1.005	52.806	0.822	0.822
FW3		58.438	1.242	47.041	0.817	0.817

126

Output Excerpts NELS Two-Level Longitudinal Factor Analysis With Covariates (Continued)

Between Level						
FB1	BY					
R88		1.000	0.000	0.000	1.952	0.933
M88		1.553	0.070	22.138	3.031	0.979
S88		1.061	0.058	18.255	2.071	0.887
H88		1.065	0.053	19.988	2.078	0.814
FB2	BY					
R90		1.000	0.000	0.000	2.413	0.923
M90		1.407	0.058	24.407	3.395	1.003
S90		1.220	0.062	19.697	2.943	0.946
H90		0.973	0.047	20.496	2.348	0.829
FB3	BY					
R92		1.000	0.000	0.000	2.472	0.947
M92		1.435	0.065	22.095	3.546	0.997
S92		1.160	0.065	17.889	2.868	0.938
H92		0.963	0.041	23.244	2.380	0.871

127

Output Excerpts NELS Two-Level Longitudinal Factor Analysis With Covariates (Continued)

Between Level						
FB1	ON					
PER_ADVA		0.217	0.292	0.742	0.111	0.024
PRIVATE		0.303	0.344	0.883	0.155	0.042
CATHOLIC		-0.696	0.277	-2.512	-0.357	-0.088
MEAN_SES		2.513	0.206	12.185	1.288	0.672
FB2	ON					
PER_ADVA		0.280	0.338	0.828	0.116	0.025
PRIVATE		0.453	0.392	1.155	0.188	0.051
CATHOLIC		-0.538	0.334	-1.609	-0.223	-0.055
MEAN_SES		3.054	0.239	12.805	1.266	0.660
FB3	ON					
PER_ADVA		0.473	0.375	1.261	0.192	0.041
PRIVATE		0.673	0.435	1.547	0.272	0.074
CATHOLIC		-0.206	0.372	-0.554	-0.084	-0.021
MEAN_SES		3.142	0.258	12.169	1.271	0.663

128

Output Excerpts NELS Two-Level Longitudinal Factor Analysis With Covariates (Continued)

Residual Variances

R88	0.564	0.104	5.437	0.564	0.129
M88	0.399	0.093	4.292	0.399	0.042
S88	1.160	0.126	9.170	1.160	0.213
H88	2.203	0.203	10.839	2.203	0.338
R90	1.017	0.160	6.352	1.017	0.149
M90	-0.068	0.055	-1.225	-0.068	-0.006
S90	1.025	0.172	5.945	1.025	0.106
H90	2.518	0.216	11.636	2.518	0.313
R92	0.706	0.182	3.886	0.706	0.104
M92	0.076	0.076	1.000	0.076	0.006
S92	1.120	0.190	5.901	1.120	0.120
H92	1.810	0.211	8.599	1.810	0.242
FB1	1.979	0.245	8.066	0.520	0.520
FB2	3.061	0.345	8.875	0.526	0.526
FB3	3.010	0.409	7.363	0.493	0.493

129

Multiple-Group, Two-Level Factor Analysis With Covariates

130

NELS Data

- The data—National Education Longitudinal Study (NELS:88)
 - Base year Grade 8—followed up in Grades 10 and 12
 - Students sampled within 1,035 schools—approximately 26 students per school
 - Variables—reading, math, science, history-citizenship-geography, and background variables
- Data for the analysis—reading, math, science, history-citizenship-geography, gender, individual SES, school SES, and minority status, $n = 14,217$ with 913 schools (clusters)

131

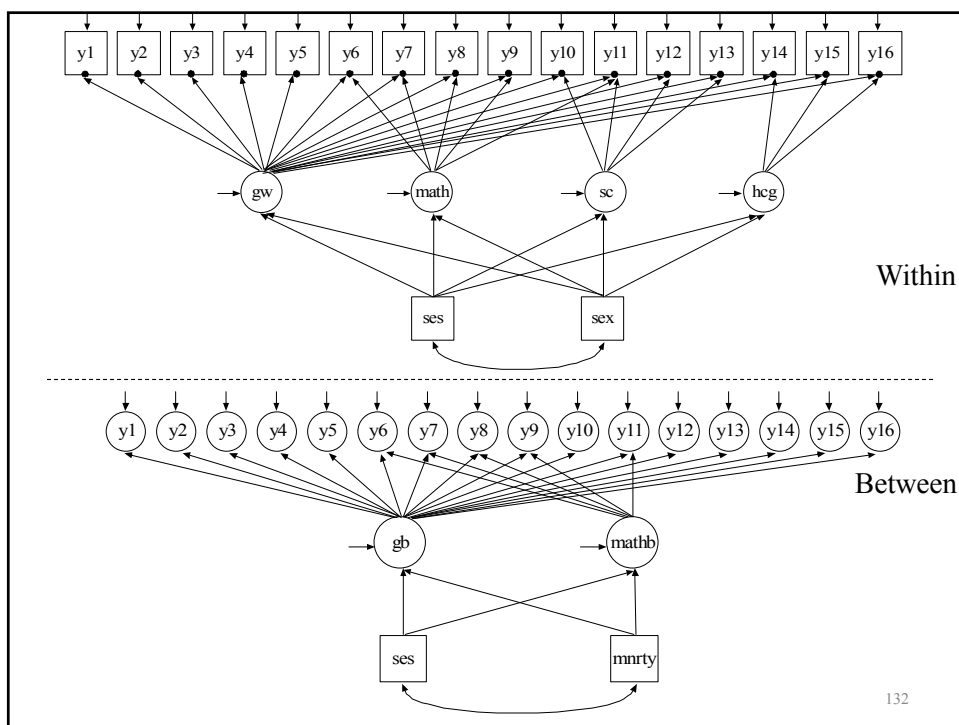

132

Input For NELS:88 Two-Group, Two-Level Model For Public And Catholic Schools

```

TITLE:      NELS:88 with listwise deletion
           disaggregated model for two groups, public and
           catholic schools

DATA:      FILE IS EX831.DAT;;

VARIABLE:  NAMES = ses y1-y16 gender cluster minority group;
           CLUSTER = cluster;
           WITHIN = gender;
           BETWEEN = minority;
           GROUPING = group(1=public 2=catholic);

DEFINE:    minority = minority/5;

ANALYSIS:  TYPE = TWOLEVEL;
           H1ITER = 2500;
           MITER = 1000;

```

133

Input For NELS:88 Two-Group, Two-Level Model For Public And Catholic Schools (Continued)

```

MODEL:     %WITHIN%
           generalw BY y1* y2-y6 y8-y16 y7@1;

           mathw BY y6* y8 y9 y11 y7@1;
           scw BY y10 y11*.5 y12*.3 y13*.2;
           hcgw BY y14*.7 y16*2 y15@1;

           generalw WITH mathw-hcgw@0;
           mathw WITH scw-hcgw@0;
           scw WITH hcgw@0;

           generalw mathw scw hcgw ON gender ses;

           %BETWEEN%
           generalb BY y1* y2-y6 y8-y16 y7@1;
           mathb BY y6* y8 y9 y11 y7@1;

           y1-y16@0;

           generalb WITH mathb@0;

           generalb mathb ON ses minority;

```

134

Output Excerpts NELS:88 Two-Group, Two-Level Model For Public And Catholic Schools

Summary Of Data

Group PUBLIC								
Number of clusters	195							
Size (s)	Cluster ID	with Size s						
1	68114	68519						
2	72872							
7	72765							
8	45991	72012						
9	68071							
10	7298	72187						
11	72463	7105	72405					
12	24083	68971	7737	68390				
13	45861	72219	72049					
14	68511	72148	72175	72176	25464			
15	68023	25071	68748	45928	7915	78324		
16	45362	7403	72415	77204	77219	72456		
17	45502	68487	45824	7203	24948	7829	72612	7892
	25835	7591	68155	68295				

135

Output Excerpts NELS:88 Two-Group, Two-Level Model For Public And Catholic Schools (Continued)

18	72133	25580	24910	68614	25074	72990	68328	25404
	7348							
19	7671	68662	68671	45385	7438	7332	25615	72799
	68340	72956	25642	25658	24856	78283	68030	
20	72617	72715	7211	25422	7330	72292	72060	72993
	7451	68461	78162	78232	72170	25130		
21	45394	7193	68180	24589	7205	25894	25958	68391
	77254	77634	68448	45271	7584	25227	78598	
22	68254	68397	68648	72768	7192	7117	7119	68753
	24813							
23	68456	25361	7157	25702	25804	45620	24858	7658
	25163	45041	77351	45183	77684	78101	68788	68817
	7792	78311	68048	68453				
24	77222	24053	7000	77403	24138	68297	78011	25536
	7778	72042	25360	25977	45747	7616	78886	
25	68906	68720	25354	68427	72833	77268	7269	68520
	77537	72075						
26	72973	45555	24828	68315	45087	25328	77710	25848
27	45831	25618	68652	72080	45900	25208	45452	7103

136

Output Excerpts NELS:88 Two-Group, Two-Level Model For Public And Catholic Schools (Continued)

28	25666	68809	25076	25224	68551
30	7343	45978	25722	45924	
31	77109	7230	68855		
32	25178				
33	45330	25745	25825		
35	25667				
36	72129				
37	25834				
38	45287				
39	45197	7090			
43	45366				

137

Output Excerpts NELS:88 Two-Group, Two-Level Model For Public And Catholic Schools (Continued)

Group PUBLIC

Number of clusters 195
Average cluster size 21.292

Estimated Intraclass Correlations for the Y Variables

Variable	Intraclass Correlation	Variable	Intraclass Correlation	Variable	Intraclass Correlation
Y1	.111	Y7	.100	Y12	.115
Y2	.105	Y8	.124	Y13	.185
Y3	.213	Y9	.069	Y14	.094
Y4	.160	Y10	.147	Y15	.132
Y5	.081	Y11	.105	Y16	.159
Y6	.159				

138

Output Excerpts NELS:88 Two-Group, Two-Level Model For Public And Catholic Schools (Continued)

Group CATHOLIC

Number of clusters 40
Average cluster size 26.016

Estimated Intraclass Correlations for the Y Variables

Variable	Intraclass Correlation	Variable	Intraclass Correlation	Variable	Intraclass Correlation
Y1	.010	Y7	.029	Y12	.056
Y2	.039	Y8	.061	Y13	.176
Y3	.180	Y9	.056	Y14	.078
Y4	.091	Y10	.079	Y15	.071
Y5	.055	Y11	.056	Y16	.154
Y6	.118				

139

Output Excerpts NELS:88 Two-Group, Two-Level Model For Public And Catholic Schools (Continued)

Tests Of Model Fit

Loglikelihood

Value	1716.922*
Degrees of Freedom	575
P-Value	0.0000
Scaling Correction Factor for MLR	0.872

Chi-Square Test of Model

Value	35476.471
Degrees of Freedom	608
P-Value	0.0000

CFI/TLI

CFI	0.967
TLI	0.965

Loglikelihood

H0 Value	-130332.921
H1 Value	-129584.053

140

Output Excerpts NELS:88 Two-Group, Two-Level Model For Public And Catholic Schools (Continued)

		Estimates	S.E.	Est./S.E.	Std	StdYX
Group Public Within Level						
GENERALW	ON					
	GENDER	-0.193	0.029	-6.559	-0.256	-0.128
	SES	0.233	0.016	14.269	0.309	0.279
MATHW	ON					
	GENDER	0.266	0.025	10.534	0.510	0.255
	SES	0.054	0.014	3.879	0.103	0.093
SCW	ON					
	GENDER	0.452	0.032	14.005	0.961	0.480
	SES	0.018	0.015	1.244	0.039	0.035
HCGW	ON					
	GENDER	0.152	0.023	6.588	0.681	0.341
	SES	0.002	0.007	0.239	0.007	0.007

141

Output Excerpts NELS:88 Two-Group, Two-Level Model For Public And Catholic Schools (Continued)

		Estimates	S.E.	Est./S.E.	Std	StdYX
Group Catholic Within Level						
GENERALW	ON					
	GENDER	-0.294	0.059	-5.000	-0.403	-0.201
	SES	0.169	0.021	7.892	0.232	0.193
MATHW	ON					
	GENDER	0.332	0.051	6.478	0.627	0.313
	SES	-0.030	0.017	-1.707	-0.056	-0.047
SCW	ON					
	GENDER	0.555	0.063	8.860	1.226	0.613
	SES	-0.022	0.014	-1.592	-0.049	-0.041
HCGW	ON					
	GENDER	0.160	0.029	5.610	0.785	0.392
	SES	0.001	0.007	0.089	0.003	0.002

142

Output Excerpts NELS:88 Two-Group, Two-Level Model For Public And Catholic Schools (Continued)

	Estimates	S.E.	Est./S.E.	Std	StdYX
Group Public Between Level					
GENERALB ON					
SES	0.505	0.079	6.390	1.244	0.726
MINORITY	-0.217	0.088	-2.452	-0.534	-0.188
MATHB ON					
SES	0.198	0.070	2.825	0.984	0.574
MINORITY	-0.031	0.087	-0.354	-0.153	-0.054
GENERALB WITH MATHB	0.000	0.000	0.000	0.000	0.000
Intercepts					
GENERALB	0.000	0.000	0.000	0.000	0.000
MATHB	0.000	0.000	0.000	0.000	0.000

143

Output Excerpts NELS:88 Two-Group, Two-Level Model For Public And Catholic Schools (Continued)

	Estimates	S.E.	Est./S.E.	Std	StdYX
Group Catholic Between Level					
GENERALB ON					
SES	0.262	0.067	3.929	0.975	0.538
MINORITY	-0.327	0.069	-4.707	-0.216	-0.573
MATHB ON					
SES	0.205	0.071	2.901	0.746	0.412
MINORITY	-0.213	0.095	-2.241	-0.778	-0.367
GENERALB WITH MATHB	0.000	0.000	0.000	0.000	0.000
Intercepts					
GENERALB	0.466	0.163	2.854	1.734	1.734
MATHB	0.573	0.177	3.239	2.087	2.087

144

Further Readings On Two-Level Factor Analysis

- Harnqvist, K., Gustafsson, J.E., Muthén, B., & Nelson, G. (1994). Hierarchical models of ability at class and individual levels. Intelligence, 18, 165-187. (#53)
- Hox, J. (2002). Multilevel analysis. Techniques and applications. Mahwah, NJ: Lawrence Erlbaum
- Longford, N. T., & Muthén, B. (1992). Factor analysis for clustered observations. Psychometrika, 57, 581-597. (#41)
- Muthén, B. (1989). Latent variable modeling in heterogeneous populations. Psychometrika, 54, 557-585. (#24)
- Muthén, B. (1990). Mean and covariance structure analysis of hierarchical data. Paper presented at the Psychometric Society meeting in Princeton, NJ, June 1990. UCLA Statistics Series 62. (#32)
- Muthén, B. (1991). Multilevel factor analysis of class and student achievement components. Journal of Educational Measurement, 28, 338-354. (#37)

145

Further Readings On Two-Level Factor Analysis (Continued)

- Muthén, B. (1994). Multilevel covariance structure analysis. In J. Hox & I. Kreft (eds.), Multilevel Modeling, a special issue of Sociological Methods & Research, 22, 376-398. (#55)
- Muthen, B., Khoo, S.T. & Gustafsson, J.E. (1997). Multilevel latent variable modeling in multiple populations. Under review Sociological Methods & Research.
- Muthén, B. & Asparouhov, T. (2011). Beyond multilevel regression modeling: Multilevel analysis in a general latent variable framework. In J. Hox & J.K. Roberts (eds), The Handbook of Advanced Multilevel Analysis, pp 15-40. New York: Taylor and Francis.

146

Two-Level Structural Equation Modeling

147

Predicting Juvenile Delinquency From First Grade Aggressive Behavior. Two-Level Logistic Regression On A Factor

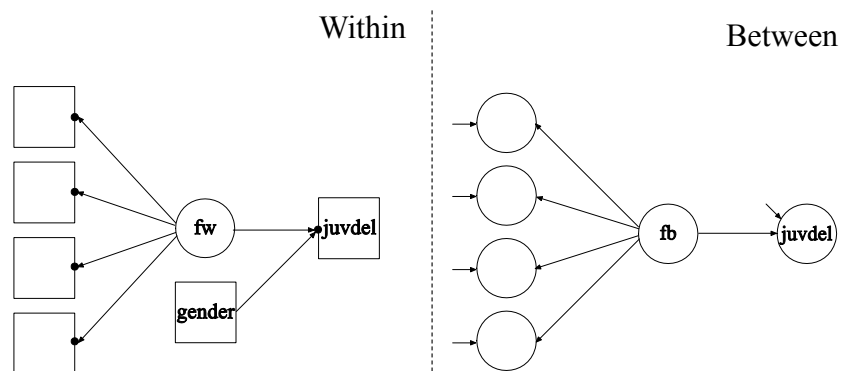

148

Input Excerpts Two-Level Logistic Regression On A Factor

```

VARIABLE:   CLUSTER=classrm;
            USEVAR = juv99 gender stub1F bkRule1F harm01F
            bkThin1F yell1F takeP1F fight1F lies1F tease1F;
            CATEGORICAL = juv99;
            MISSING = ALL (999);
            WITHIN = gender;

ANALYSIS:   TYPE = TWOLEVEL;

MODEL:      %WITHIN%
            fw BY stub1F bkRule1F harm01F bkThin1F yell1F
            takeP1F fight1F lies1F tease1F;
            juv99 ON gender fw;
            %BETWEEN%
            fb BY stub1F bkRule1F harm01F bkThin1F yell1F
            takeP1F fight1F lies1F tease1F;
            juv99 ON fb;

OUTPUT:     TECH1 TECH8;

```

149

Two-Level SEM With Categorical Factor Indicators On The Within Level And Cluster-Level Continuous Observed And Random Intercept Factor Indicators On the Between Level

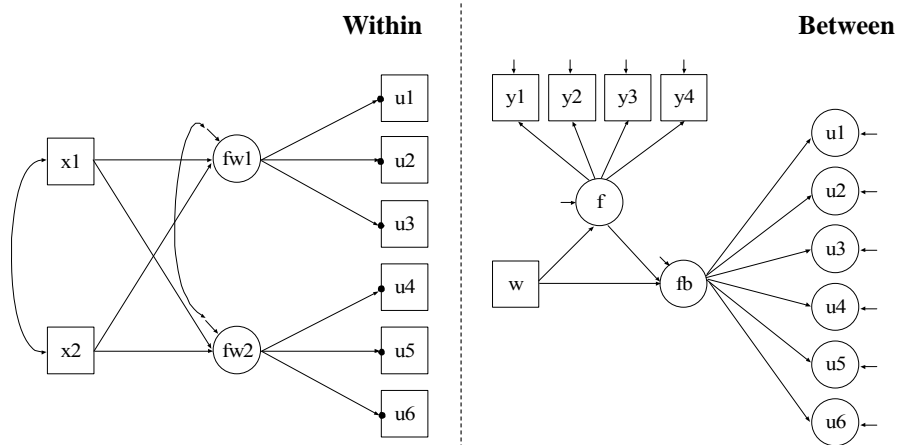

150

Two-Level SEM With Categorical Factor Indicators On The Within Level And Cluster-Level Continuous Observed And Random Intercept Factor Indicators On the Between Level

```

TITLE:          this is an example of a two-level SEM with
                  categorical factor indicators on the within level
                  and cluster-level continuous observed and random
                  intercept factor indicators on the between level

DATA:          FILE IS ex9.9.dat;
VARIABLE:     NAMES ARE u1-u6 y1-y4 x1 x2 w clus;
                  CATEGORICAL = u1-u6;
                  WITHIN = x1 x2;
                  BETWEEN = w y1-y4;
                  CLUSTER IS clus;
ANALYSIS:     TYPE IS TWOLEVEL;
                  ESTIMATOR = WLSMV;
MODEL:
    %WITHIN%
    fw1 BY u1-u3;
    fw2 BY u4-u6;
    fw1 fw2 ON x1 x2;

```

151

Two-Level SEM With Categorical Factor Indicators On The Within Level And Cluster-Level Continuous Observed And Random Intercept Factor Indicators On the Between Level

```

    %BETWEEN%
    fb BY u1-u6;
    f BY y1-y4;
    fb ON w f;
    f ON w;
SAVEDATA:    SWMATRIX = ex9.9sw.dat;

```

152

Two-Level SEM: Random Slopes For Regressions Among Factors

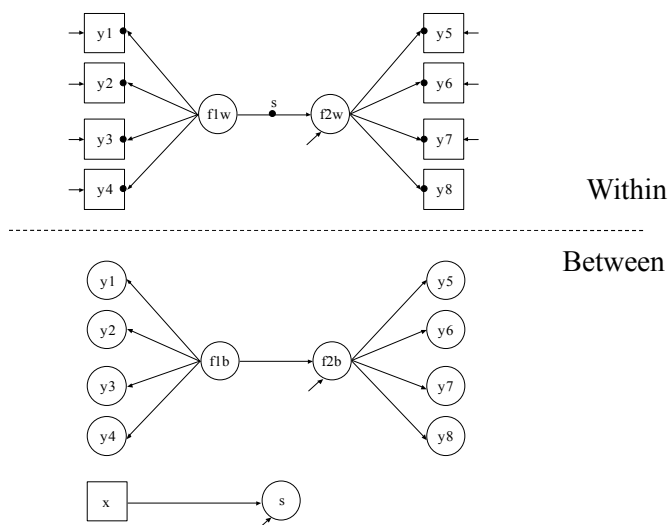

Two-Level Estimators In Mplus

- Maximum-likelihood:
 - Outcomes: Continuous, censored, binary, ordered and unordered categorical, counts and combinations
 - Random intercepts and slopes; individually-varying times of observation; random slopes for time-varying covariates; random slopes for dependent variables; random slopes for latent independent and dependent variables
 - Missing data
- Limited information weighted least-squares:
 - Outcomes: Continuous, categorical, and combinations
 - Random intercepts
 - Missing data
- Muthen's limited information estimator (MUML):
 - Outcomes: Continuous
 - Random intercepts
 - No missing data

Non-normality robust SEs and chi-square test of model fit.

154

Practical Issues Related To The Analysis Of Multilevel Data

Size Of The Intraclass Correlation

- The importance of the size of an intraclass correlation depends on the size of the clusters
- Small intraclass correlations can be ignored but important information about between-level variability may be missed by conventional analysis
- Intraclass correlations are attenuated by individual-level measurement error
- Effects of clustering not always seen in intraclass correlations

155

Practical Issues Related To The Analysis Of Multilevel Data (Continued)

Sample Size

- There should be at least 30-50 between-level units (clusters)
- Clusters with only one observation are allowed
- More clusters than between-level parameters

156

Steps In SEM Multilevel Analysis For Continuous Outcomes

- 1) Explore SEM model using the sample covariance matrix from the total sample
- 2) Estimate the SEM model using the pooled-within sample covariance matrix with sample size $n - G$
- 3) Investigate the size of the intraclass correlations and DEFF's
- 4) Explore the between structure using the estimated between covariance matrix with sample size G
- 5) Estimate and modify the two-level model suggested by the previous steps

Muthén, B. (1994). Multilevel covariance structure analysis. In J. Hox & I. Kreft (eds.), *Multilevel Modeling*, a special issue of *Sociological Methods & Research*, 22, 376-398. (#55)

157

Multivariate Approach To Multilevel Modeling

158

Multivariate Modeling Of Family Members

- Multilevel modeling: clusters independent, model for between- and within-cluster variation, members of a cluster statistically equivalent
- Multivariate approach: clusters independent, model for all variables for each cluster member, different parameters for different cluster members.
 - Used in latent variable growth modeling where the cluster members are the repeated measures over time
 - Allows for different cluster sizes by missing data techniques
 - More flexible than the multilevel approach, but computationally convenient only for applications with small cluster sizes (e.g. twins, spouses)

159

Twin Modeling

160

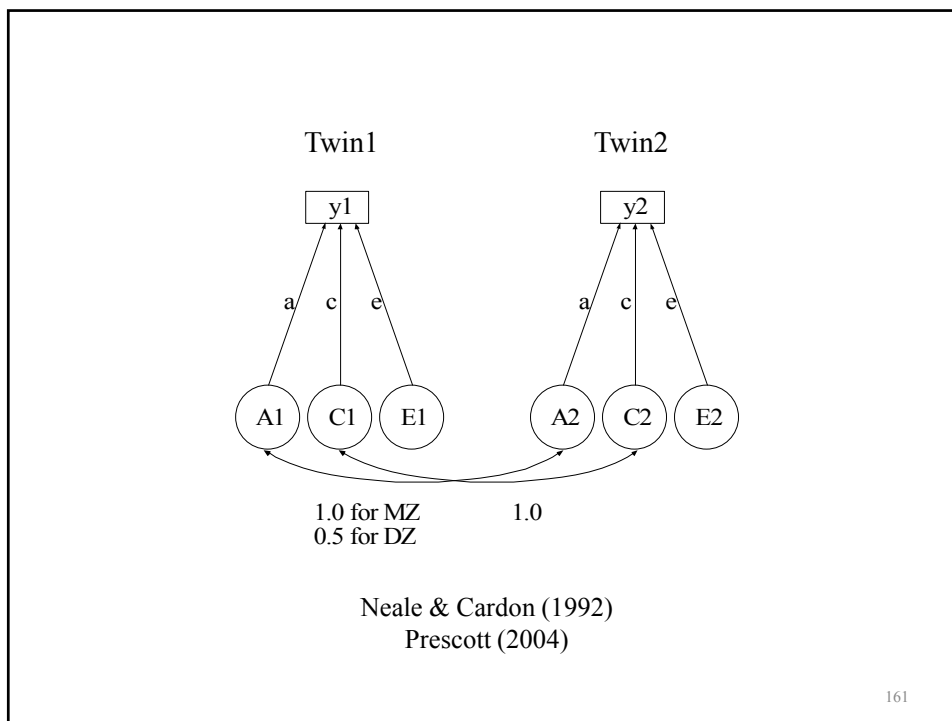

**Two-Level Mixture Modeling:
Within-Level Latent Classes**

Regression Mixture Analysis

163

Two-Level Regression Mixture Analysis

- Conventional (non-mixture) analysis:
 - Unobserved heterogeneity among level 2 units
 - Continuous latent variables (random effects)
- Mixture analysis:
 - Unobserved heterogeneity among level 1 units and level 2 units
 - Categorical and continuous latent variables

164

Two-Level Regression Mixture Model

$$y_{ij} | C_{ij}=c = \beta_{0cj} + \beta_{1cj} x_{ij} + r_{ij}, \quad (3)$$

$$P(C_{ij} = c | z_{ij}) = \frac{e^{a_{cj} + b_c z_{ij}}}{\sum_{s=1}^K e^{a_{sj} + b_s z_{ij}}} \quad (4)$$

$$\beta_{0cj} = \gamma_{00c} + \gamma_{01c} w_{0j} + u_{0j}, \quad (5)$$

$$\beta_{1cj} = \gamma_{10c} + \gamma_{11c} w_{1j} + u_{1j}, \quad (6)$$

$$a_{cj} = \gamma_{20c} + \gamma_{21c} w_{2j} + u_{2cj} \quad (7)$$

Muthén & Asparouhov (2009), JRSS-A

165

Two-Level Data

- Education studies of students within schools
 - LSAY (3,000 students in 54 schools, grades 7-12)
 - NELS (14,000 students in 900 schools, grades 8-12),
 - ECLS (22,000 students in 1,000 schools, K- grade 8)
- Public health studies of patients within hospitals, individuals within counties

166

NELS Data: Grade 12 Math Related To Gender And SES

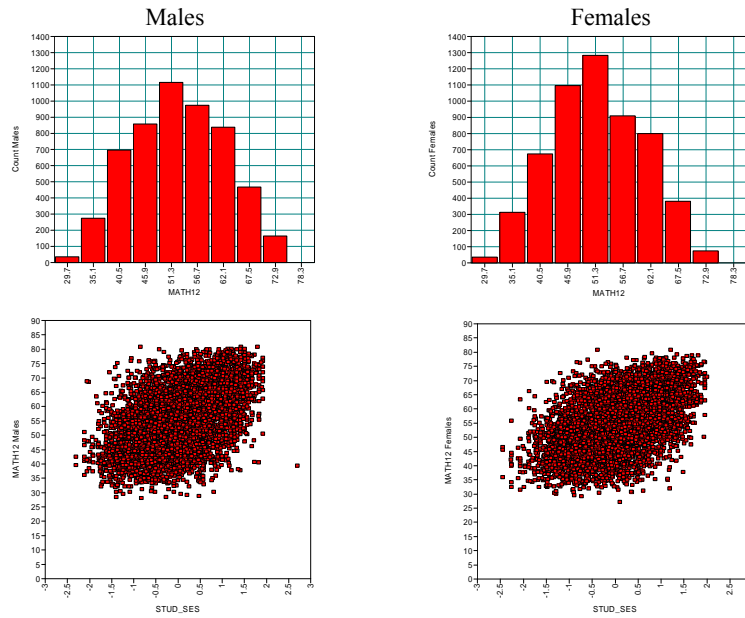

167

NELS Two-Level Math Achievement Regression

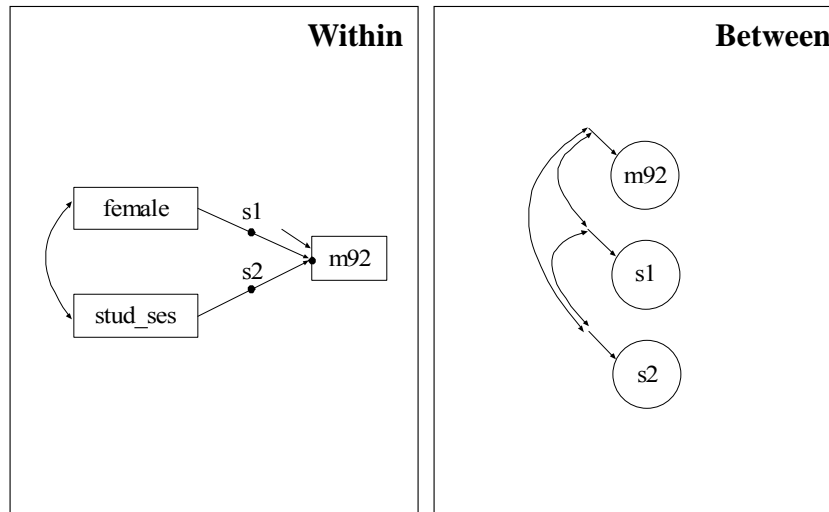

168

Output Excerpts NELS Two-Level Regression

	Estimates	S.E.	Est./S.E.
Between Level			
Means			
M92	55.279	0.174	317.706
S_FEMALE	-0.850	0.188	-4.507
S_SES	5.450	0.132	41.228
Variiances			
M92	11.814	1.197	9.870
S_FEMALE	5.762	1.426	4.041
S_SES	0.905	0.538	1.682
S_FEMALE WITH			
M92	-4.936	1.071	-4.610
S_SES	0.068	0.635	0.107
S_SES WITH			
M92	1.314	0.541	2.431

169

Random Effect Estimates For Each School: Slopes For Female Versus Intercepts For Math

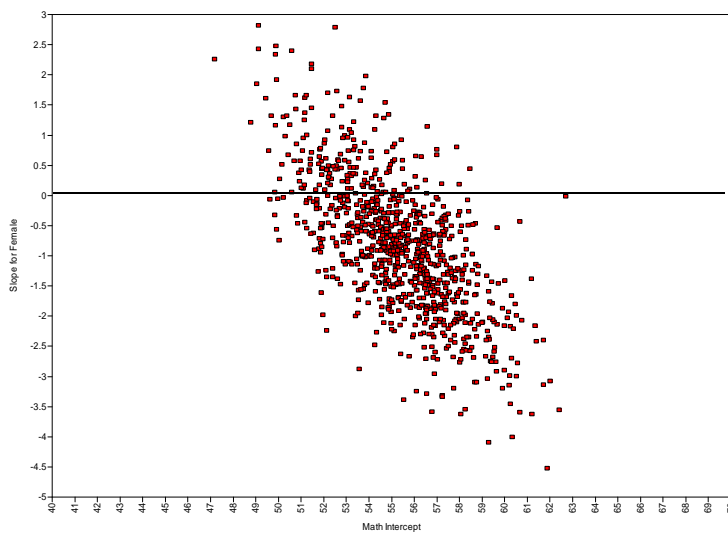

170

Is The Conventional Two-Level Regression Model Sufficient?

- Conventional Two-Level Regression of Math Score Related to Gender and Student SES
 - Loglikelihood = -39,512, number of parameters = 10, BIC = 79,117
 - New Model
 - Loglikelihood = -39,368, number of parameters = 12, BIC = 78,848
- Which model would you choose?

171

Two-Level Regression With Latent Classes For Students

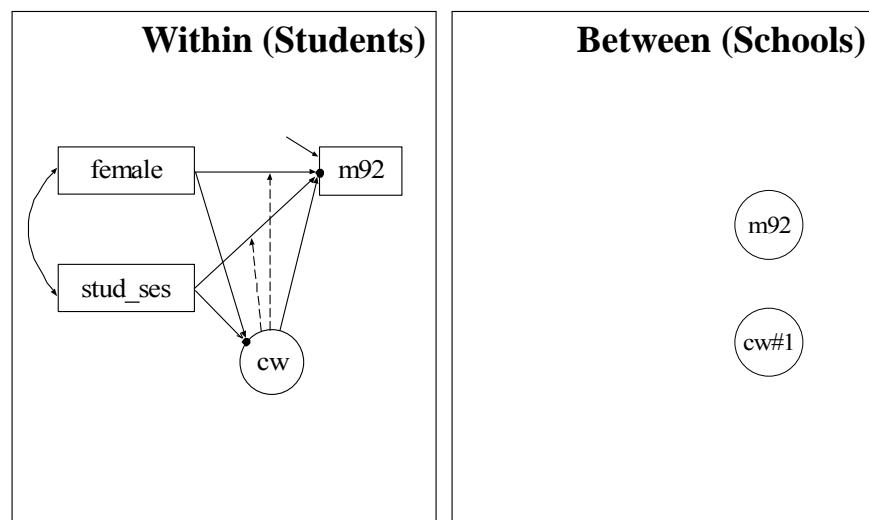

172

Model Results For NELS Two-Level Regression Of Math Score Related To Gender And Student SES

Model	Loglikelihood	# parameters	BIC
(1) Conventional 2-level regression with random intercepts and random slopes	-39,512	10	79,117
(2) Two-level regression mixture, 2 latent classes for students	-39,368	12	78,848
(3) Two-level regression mixture, 3 latent classes for students	-39,280	19	78,736

173

Estimated Two-Level Regression Mixture 3 Latent Classes For Students With

- Estimated Female slope means for the 3 latent classes for students do not include positive values.
- The class with the least Female disadvantage (right-most bar) has the lowest math mean

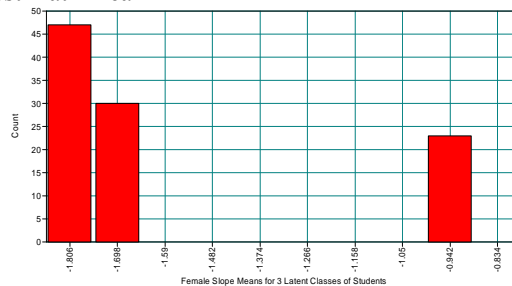

- Significant between-level variation in cw (the random mean of the latent class variable for students): Schools have a significant effect on latent class membership for students

174

Input For Two-Level Regression With Latent Classes For Students

```

TITLE:    NELS 2-level regression
DATA:    FILE = comp.dat;
         FORMAT = 2f7.0 f11.4 13f5.2 79f8.2 f11.7;
VARIABLE:
         NAMES = school m92 female stud_ses;
         CLUSTER = school;
         USEV = m92 female stud_ses;
         WITHIN = female stud_ses;
         CENTERING = GRANDMEAN(stud_ses);
         CLASSES = cw(3);
ANALYSIS:
         TYPE = TWOLEVEL MIXTURE;
         PROCESS = 2;
         INTERACTIVE = control.dat;
         !STARTS = 1000 100;
         STARTS = 0;

```

175

Input For Two-Level Regression With Latent Classes For Students (Continued)

```

MODEL:
         %WITHIN%
         %OVERALL%
         m92 ON female stud_ses;
         cw#1-cw#2 ON female stud_ses;
! [m92] class-varying by default
         %cw#1%
         m92 ON female stud_ses;
         %cw#2%
         m92 ON female stud_ses;
         %cw#3%
         m92 ON female stud_ses;
         %BETWEEN%
         %OVERALL%
         f BY cw#1 cw#2;

```

176

Cluster-Randomized Trials And NonCompliance

177

Randomized Trials With NonCompliance

- Tx group (compliance status observed)
 - Compliers
 - Noncompliers
- Control group (compliance status unobserved)
 - Compliers
 - NonCompliers

Compliers and Noncompliers are typically not randomly equivalent subgroups.

Four approaches to estimating treatment effects:

1. Tx versus Control (Intent-To-Treat; ITT)
2. Tx Compliers versus Control (Per Protocol)
3. Tx Compliers versus Tx NonCompliers + Control (As-Treated)
4. Mixture analysis (Complier Average Causal Effect; CACE):
 - Tx Compliers versus Control Compliers
 - Tx NonCompliers versus Control NonCompliers

CACE: Little & Yau (1998) in Psychological Methods

178

Randomized Trials with NonCompliance: Complier Average Causal Effect (CACE) Estimation

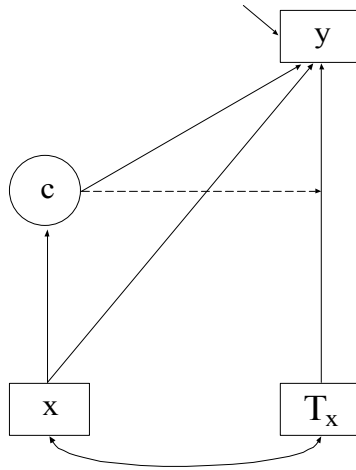

179

Two-Level Regression Mixture Modeling: Cluster-Randomized CACE

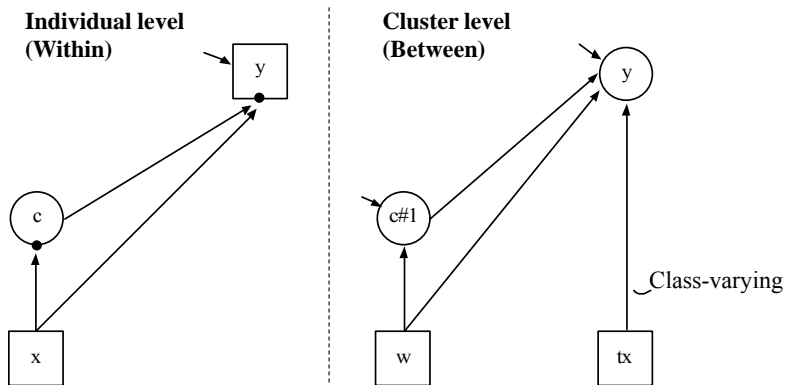

180

Further Readings On Non-Compliance Modeling

- Dunn, G., Maracy, M., Dowrick, C., Ayuso-Mateos, J.L., Dalgard, O.S., Page, H., Lehtinen, V., Casey, P., Wilkinson, C., Vasquez-Barquero, J.L., & Wilkinson, G. (2003). Estimating psychological treatment effects from a randomized controlled trial with both non-compliance and loss to follow-up. *British Journal of Psychiatry*, 183, 323-331.
- Jo, B. (2002). Statistical power in randomized intervention studies with noncompliance. *Psychological Methods*, 7, 178-193.
- Jo, B. (2002). Model misspecification sensitivity analysis in estimating causal effects of interventions with noncompliance. *Statistics in Medicine*, 21, 3161-3181.
- Jo, B. (2002). Estimation of intervention effects with noncompliance: Alternative model specifications. *Journal of Educational and Behavioral Statistics*, 27, 385-409.

181

Further Readings On Non-Compliance Modeling: Two-Level Modeling

- Jo, B., Asparouhov, T. & Muthén, B. (2008). Intention-to-treat analysis in cluster randomized trials with noncompliance. *Statistics in Medicine*, 27, 5565-5577.
- Jo, B., Asparouhov, T., Muthén, B. O., Ialongo, N. S., & Brown, C. H. (2008). Cluster Randomized Trials with Treatment Noncompliance. *Psychological Methods*, 13, 1-18.

182

Latent Class Analysis

183

Latent Class Analysis

Item	Class 1	Class 2	Class 3	Class 4
inatt1	0.98	0.80	0.28	0.18
inatt2	0.92	0.82	0.25	0.18
hyper1	0.98	0.70	0.40	0.18
hyper2	0.85	0.78	0.35	0.15

```

graph TD
    x[x] --> c((c))
    c --> inatt1[inatt1]
    c --> inatt2[inatt2]
    c --> hyper1[hyper1]
    c --> hyper2[hyper2]
    
```

184

Two-Level Latent Class Analysis

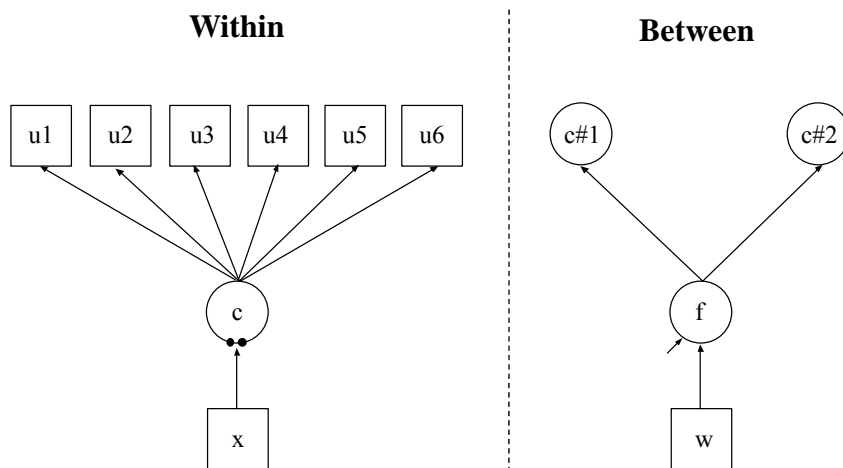

185

Input For Two-Level Latent Class Analysis

```

TITLE:      this is an example of a two-level LCA with
             categorical latent class indicators

DATA:      FILE IS ex10.3.dat;

VARIABLE:  NAMES ARE u1-u6 x w c clus;
             USEVARIABLES = u1-u6 x w;
             CATEGORICAL = u1-u6;
             CLASSES = c (3);
             WITHIN = x;
             BETWEEN = w;
             CLUSTER = clus;

ANALYSIS:  TYPE = TWOLEVEL MIXTURE;

```

186

Input For Two-Level Latent Class Analysis (Continued)

```

MODEL:      %WITHIN%
            %OVERALL%
            c#1 c#2 ON x;

            %BETWEEN%
            %OVERALL%
            f BY c#1 c#2;
            f ON w;

OUTPUT:     TECH1 TECH8;

```

187

Multilevel Latent Class Analysis: An Application Of Adolescent Smoking Typologies With Individual And Contextual Predictors

- Latent classes of cigarette smoking among 10,772 European American females in 9th grade
- 206 rural communities across the U.S.
- Parametric and non-parametric approach for estimating a MLCA
- Individual and contextual predictors of the smoking typologies
- Both latent class and indicator-specific random effects models are explored

Source: Henry, K & Muthen, B (2010). Multilevel latent class analysis: An application of adolescent smoking typologies with individual and contextual predictors. Structural Equation Modeling, 17, 193-215.

188

Multilevel Latent Class Analysis Application (Continued)

Best model:

- Three level 1 latent smoking classes (heavy smokers, moderate smokers, non-smokers)
- Two random effects to account for variation in the probability of level 1 latent class membership across communities
- A random factor for the indicator-specific level 2 variances
- Several covariates at the individual and contextual level were useful in predicting latent classes of cigarette smoking as well as the individual indicators of the latent class model

189

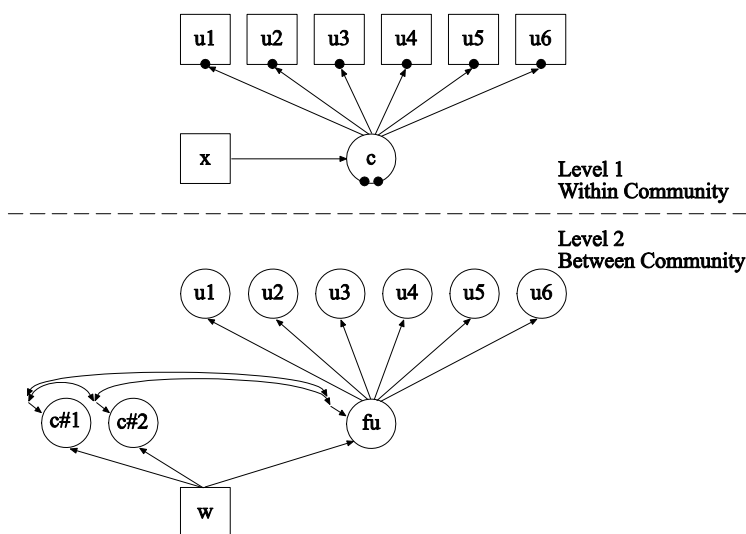

190

Further Readings On Multilevel Latent Class Analysis

- Asparouhov, T., & Muthen, B. (2008). Multilevel mixture models. In G. R. Hancock & K. M. Samuelsen (Eds.), Advances in latent variable mixture models, pp. 27-51. Charlotte, NC: Information Age Publishing, Inc.
- Bijmolt, T. H., Paas, L. J., & Vermunt, J. K. (2004). Country and consumer segmentation: Multi-level latent class analysis of financial product ownership. International Journal of Research in Marketing, 21, 323-340.
- Vermunt, J. K. (2003). Multilevel latent class models. Sociological Methodology, 33, 213-239.
- Vermunt, J. K. (2008). Latent class and finite mixture models for multilevel data sets. Statistical Methods in Medical Research, 17(1), 33-51.

191

Two-Level Mixture Modeling: Between-Level Latent Classes

192

Regression Mixture Analysis

193

NELS Two-Level Regression With Latent Classes For Students

<p>Within (Students)</p>	<p>Between (Schools)</p>
---------------------------------	---------------------------------

194

NELS Two-Level Regression With Latent Classes For Students And Schools

Within (Students)

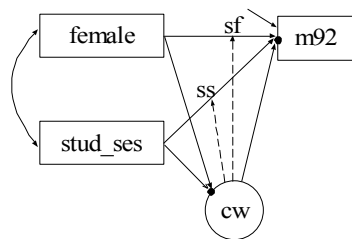

Between (Schools)

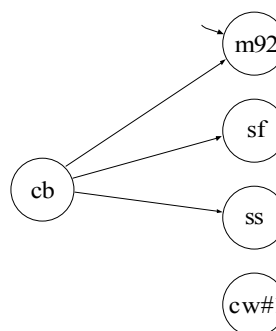

195

Model Results For NELS Two-Level Regression Of Math Score Related To Gender And Student SES

Model	Loglikelihood	# parameters	BIC
(1) Conventional 2-level regression with random intercepts and random slopes	-39,512	10	79,117
(2) Two-level regression mixture, 2 latent classes for students	-39,368	12	78,848
(3) Two-level regression mixture, 3 latent classes for students	-39,280	19	78,736
(4) Two-level regression mixture, 2 latent classes for schools, 2 latent classes for students	-39,348	19	78,873
(5) Two-level regression mixture, 2 latent classes for schools, 3 latent classes for students	-39,260	29	78,789

196

Latent Class Analysis

197

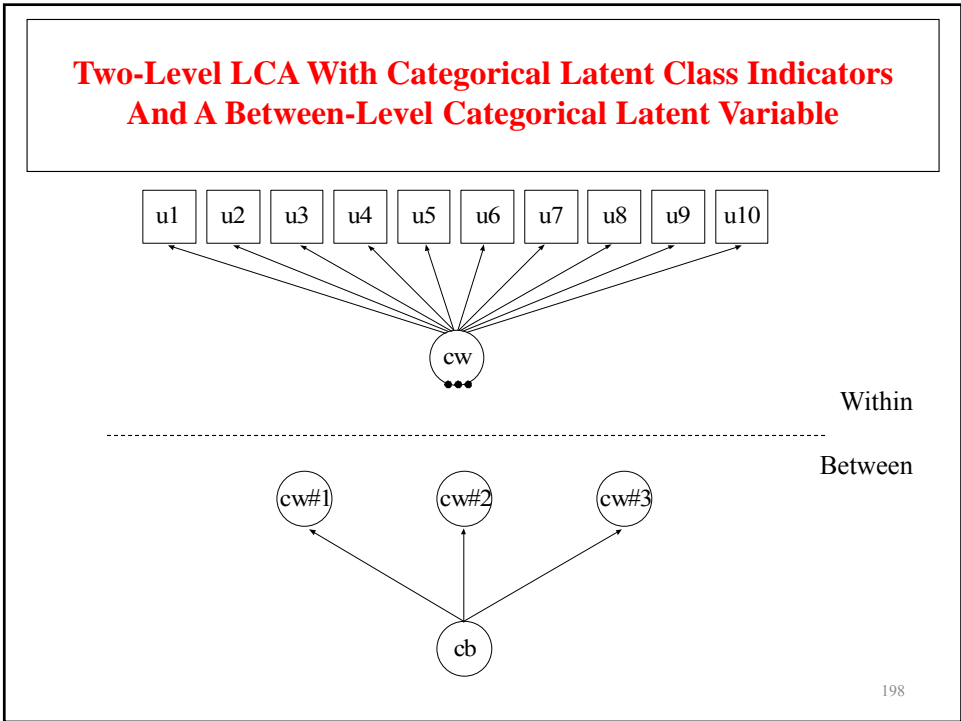

Input For Two-Level Latent Class Analysis

```

TITLE:          this is an example of a two-level LCA with
                 categorical latent class indicators and a between-
                 level categorical latent variable
DATA:          FILE = ex4.dat;
VARIABLE:      NAMES ARE u1-u10 dumb dumw clus;
                 USEVARIABLES = u1-u10;
                 CATEGORICAL = u1-u10;
                 CLASSES = cb(5) cw(4);
                 WITHIN = u1-u10;
                 BETWEEN = cb;
                 CLUSTER = clus;
ANALYSIS:      TYPE = TWOLEVEL MIXTURE;
                 PROCESSORS = 2;
                 STARTS = 100 10;
MODEL:
                 %WITHIN%
                 %OVERALL%
                 %BETWEEN%
                 %OVERALL%
                 cw#1-cw#3 ON cb#1-cb#4;

```

199

Input For Two-Level Latent Class Analysis (Continued)

```

MODEL cw:
                 %WITHIN%
                 %cw#1%
                 [u1$1-u10$1];
                 [u1$2-u10$2];
                 %cw#2%
                 [u1$1-u10$1];
                 [u1$2-u10$2];
                 %cw#3%
                 [u1$1-u10$1];
                 [u1$2-u10$2];
                 %cw#4%
                 [u1$1-u10$1];
                 [u1$2-u10$2];
OUTPUT:        TECH1 TECH8;

```

200

References

(To request a Muthén paper, please email bmuthen@ucla.edu.)

Cross-sectional Data

- Asparouhov, T. (2005). Sampling weights in latent variable modeling. Structural Equation Modeling, 12, 411-434.
- Asparouhov, T. & Muthén, B. (2007). Computationally efficient estimation of multilevel high-dimensional latent variable models. Proceedings of the 2007 JSM meeting in Salt Lake City, Utah, Section on Statistics in Epidemiology.
- Asparouhov, T., & Muthén, B. (2008). Multilevel mixture models. In G. R. Hancock & K. M. Samuelsen (Eds.), Advances in latent variable mixture models, pp. 27-51. Charlotte, NC: Information Age Publishing, Inc.
- Bijmolt, T. H., Paas, L. J., & Vermunt, J. K. (2004). Country and consumer segmentation: Multi-level latent class analysis of financial product ownership. International Journal of Research in Marketing, 21, 323-340.
- Chambers, R.L. & Skinner, C.J. (2003). Analysis of survey data. Chichester: John Wiley & Sons.
- Enders, C.K. & Tofighi, D. (2007). Centering predictor variables in cross-sectional multilevel models: A new look at an old Issue. Psychological Methods, 12, 121-138.

201

References (Continued)

- Fox, J.P. (2005). Multilevel IRT using dichotomous and polytomous response data. British Journal of Mathematical and Statistical Psychology, 58, 145-172.
- Fox, J.P. & Glas, C.A.W. (2001). Bayesian estimation of a multilevel IRT model using Gibbs. Psychometrika, 66, 269-286.
- Harnqvist, K., Gustafsson, J.E., Muthén, B. & Nelson, G. (1994). Hierarchical models of ability at class and individual levels. Intelligence, 18, 165-187. (#53)
- Heck, R.H. (2001). Multilevel modeling with SEM. In G.A. Marcoulides & R.E. Schumacker (eds.), New developments and techniques in structural equation modeling (pp. 89-127). Lawrence Erlbaum Associates.
- Hox, J. (2002). Multilevel analysis. Techniques and applications. Mahwah, NJ: Lawrence Erlbaum.
- Jo, B., Asparouhov, T. & Muthén, B. (2008). Intention-to-treat analysis in cluster randomized trials with noncompliance. Statistics in Medicine, 27, 5565-5577.
- Jo, B., Asparouhov, T., Muthén, B., Jalongo, N.S. & Brown, C.H. (2008). Cluster randomized trials with treatment non-compliance. Psychological Methods, 13, 1-18.

202

References (Continued)

- Kaplan, D. & Elliott, P.R. (1997). A didactic example of multilevel structural equation modeling applicable to the study of organizations. Structural Equation Modeling: A Multidisciplinary Journal, 4, 1-24.
- Kaplan, D. & Ferguson, A.J (1999). On the utilization of sample weights in latent variable models. Structural Equation Modeling, 6, 305-321.
- Kaplan, D. & Kresiman, M.B. (2000). On the validation of indicators of mathematics education using TIMSS: An application of multilevel covariance structure modeling. International Journal of Educational Policy, Research, and Practice, 1, 217-242.
- Korn, E.L. & Graubard, B.I (1999). Analysis of health surveys. New York: John Wiley & Sons.
- Kreft, I. & de Leeuw, J. (1998). Introducing multilevel modeling. Thousand Oakes, CA: Sage Publications.
- Larsen & Merlo (2005). Appropriate assessment of neighborhood effects on individual health: Integrating random and fixed effects in multilevel logistic regression. American Journal of Epidemiology, 161, 81-88.
- Longford, N.T., & Muthén, B. (1992). Factor analysis for clustered observations. Psychometrika, 57, 581-597. (#41)

203

References (Continued)

- Lüdtke, O., Marsh, H.W., Robitzsch, A., Trautwein, U., Asparouhov, T., & Muthén, B. (2008). The multilevel latent covariate model: A new, more reliable approach to group-level effects in contextual studies. Psychological Methods, 13, 203-229.
- Muthén, B. (1989). Latent variable modeling in heterogeneous populations. Psychometrika, 54, 557-585. (#24)
- Muthén, B. (1990). Mean and covariance structure analysis of hierarchical data. Paper presented at the Psychometric Society meeting in Princeton, N.J., June 1990. UCLA Statistics Series 62. (#32)
- Muthén, B. (1991). Multilevel factor analysis of class and student achievement components. Journal of Educational Measurement, 28, 338-354. (#37)
- Muthén, B. (1994). Multilevel covariance structure analysis. In J. Hox & I. Kreft (eds.), Multilevel Modeling, a special issue of Sociological Methods & Research, 22, 376-398. (#55)
- Muthén, B. & Asparouhov, T. (2011). Beyond multilevel regression modeling: Multilevel analysis in a general latent variable framework. In J. Hox & J.K. Roberts (eds), The Handbook of Advanced Multilevel Analysis, pp 15-40. New York: Taylor and Francis.
- Muthén, B. & Asparouhov, T. (2009). Multilevel regression mixture analysis. Journal of the Royal Statistical Society, Series A, 172, 639-657.

204

References (Continued)

- Muthén, B., Khoo, S.T. & Gustafsson, J.E. (1997). Multilevel latent variable modeling in multiple populations. (#74)
- Muthén, B. & Satorra, A. (1995). Complex sample data in structural equation modeling. In P. Marsden (ed.), Sociological Methodology 1995, 216-316. (#59)
- Neale, M.C. & Cardon, L.R. (1992). Methodology for genetic studies of twins and families. Dordrecht, The Netherlands: Kluwer.
- Patterson, B.H., Dayton, C.M. & Graubard, B.I. (2002). Latent class analysis of complex sample survey data: application to dietary data. Journal of the American Statistical Association, 97, 721-741.
- Preacher, K., Zyphur, M. & Zhang, Z. (2010). A general multilevel SEM framework for assessing multilevel mediation. Psychological Methods, 15, 209-233.
- Prescott, C.A. (2004). Using the Mplus computer program to estimate models for continuous and categorical data from twins. Behavior Genetics, 34, 17-40.
- Raudenbush, S.W. & Bryk, A.S. (2002). Hierarchical linear models: Applications and data analysis methods. Second edition. Newbury Park, CA: Sage Publications.

205

References (Continued)

- Skinner, C.J., Holt, D. & Smith, T.M.F. (1989). Analysis of complex surveys. West Sussex, England, Wiley.
- Snijders, T. & Bosker, R. (1999). Multilevel analysis. An introduction to basic and advanced multilevel modeling. Thousand Oakes, CA: Sage Publications.
- Stapleton, L. (2002). The incorporation of sample weights into multilevel structural equation models. Structural Equation Modeling, 9, 475-502.
- Vermunt, J.K. (2003). Multilevel latent class models. In Stolzenberg, R.M. (Ed.), Sociological Methodology (pp. 213-239). New York: American Sociological Association.
- Vermunt, J. K. (2003). Multilevel latent class models. Sociological Methodology, 33, 213-239.
- Vermunt, J. K. (2008). Latent class and finite mixture models for multilevel data sets. Statistical Methods in Medical Research, 17(1), 33-51.

206

References (Continued)

Random Effects, Numerical Integration, And Non-Parametric Representation of Latent Variable Distributions

- Aitkin, M. A general maximum likelihood analysis of variance components in generalized linear models. *Biometrics*, 1999, 55, 117-128.
- Bock, R.D. & Aitkin, M. (1981). Marginal maximum likelihood estimation of item parameters: Application of an EM algorithm. *Psychometrika*, 46, 443-459.
- Skrondal, A. & Rabe-Hesketh, S. (2004). Generalized latent variable modeling. Multilevel, longitudinal, and structural equation models. London: Chapman Hall.
- Schilling, S. & Bock, R.D. (2005). High-dimensional maximum marginal likelihood item factor analysis by adaptive quadrature. *Psychometrika*, 70, 533-555.
- Vermunt, J.K. (1997). *Log-linear models for event histories*. Advanced quantitative techniques in the social sciences, vol 8. Thousand Oaks: Sage Publications.